

# Spin-on elements

## Type 80, 81 and 82

**RE 51478**

Edition: 2019-12



56796\_d

- ▶ Sizes according to **according to Bosch Rexroth standard:** 30 to 130
- ▶ Pressure differential resistance up to 5 bar [72.5 psi]
- ▶ Filter rating: 1 to 20  $\mu\text{m}$
- ▶ Filter area: max. 3820 cm<sup>2</sup> [592 in<sup>2</sup>]

### Features

- ▶ Filter media made of glass fiber material and filter paper
- ▶ Diverse connection threads available in many different versions and pressure ratings
- ▶ Max. oil cleanliness up to ISO 13/10/8 (ISO 4406)
- ▶ Large filter area in small installation area
- ▶ With bypass valve upon request
- ▶ Other models upon request

### Contents

Features	1
Ordering code spin-on elements	2 ... 4
Preferred types	5
Assignment of spin-on elements to filter series	5
Filter design	6
Function, cross-section	7
Filter variables	8, 9
Technical data preferred program	10
Operating temperature range	10
Compatibility with permitted hydraulic fluids	10
Dimensions	11
Installation station	12, 13
Filter media	14, 15
Assembly, commissioning, maintenance	16
Directives and standardization	17
Environmental safety and recycling	17

## Ordering code

### Spin-on elements

#### Type 80.

01	02	03	04	05	06
80			- S00 -		

#### Spin-on element

01	Design	80
----	--------	----

#### Size

02	According to Bosch Rexroth standard	Size	Connection thread	
		30	3/4"-16 UNF	30/20
		45	3/4"-16 UNF	45/20
		45	G3/4	45/21
		60	1"-12 UNF	60/20
		60	G3/4	60/21
		90	G1 1/4	90
		130	G1 1/4	130

#### Filtration rating in $\mu\text{m}$

03	<b>Absolute</b> (ISO 16889; $\beta_x(c) \geq 200$ )	Glass fiber material (not cleanable)	H3XL H6XL H10XL H20XL
	<b>Nominal</b>	Filter paper (not cleanable)	P10 P25

#### Pressure differential

04	Max. pressure differential of the spin-on element of 5 bar [72.5 psi]	S00
----	---	-----

#### Bypass valve

05	<b>Without</b> bypass valve	0
	<b>With</b> bypass valve – release pressure 0.3 bar [4.4 psi]	1
	<b>With</b> bypass valve – release pressure 2.0 bar [29.0 psi]	4
	<b>With</b> bypass valve – release pressure 2.5 bar [36.3 psi]	5

#### Seal

06	NBR seal	M
	FKM seal	V

#### Order example:

80.90 H10XL-S00-0-M

Material no.: R928016614

## Ordering code Spin-on elements

### Type 81.

01	02	03	04	05	06			
<b>81</b>			-	<b>S00</b>	-	<b>0</b>	-	

### Spin-on element

01	Design	<b>81</b>
----	--------	-----------

### Size

02	According to <b>Bosch Rexroth standard</b>	<b>90</b> <b>130</b>
----	--	-------------------------

### Filtration rating in $\mu\text{m}$

03	<b>Absolute</b> <b>(ISO 16889; <math>\beta_x(c) \geq 200</math>)</b>	Glass fiber material (not cleanable)	<b>H3XL</b> <b>H6XL</b> <b>H10XL</b> <b>H20XL</b>
	<b>Nominal</b>	Filter paper (not cleanable)	<b>P10</b> <b>P25</b>

### Pressure differential

04	Max. pressure differential of the spin-on element of 5 bar [72.5 psi]	<b>S00</b>
----	---	------------

### Bypass valve

05	<b>Without</b> bypass valve	<b>0</b>
----	-----------------------------	----------

### Seal

06	NBR seal	<b>M</b>
	FKM seal	<b>V</b>

### Order example:

**81.90 H10XL-S00-0-M**

**Material no.: R928035941**

## Ordering code

### Spin-on elements

#### Type 82.

01	02	03	04	05	06
82			- S00	- 0	-

#### Spin-on element

01	Design	82
----	--------	----

#### Size

02	According to <b>Bosch Rexroth Standard</b> design with UNF thread	30 45 50 60 80
	According to <b>Bosch Rexroth Standard</b> design with UN thread	30D 45D 50D 60D 80D

#### Filtration rating in $\mu\text{m}$

03	<b>Absolute</b> (ISO 16889; $\beta_x(c) \geq 200$ )	Glass fiber material (not cleanable)	H3XL H6XL H10XL H20XL
		Glass fiber material (not cleanable)	H10
	<b>Nominal</b>	Filter paper (not cleanable)	P10 P25

#### Pressure differential

04	Max. pressure differential of the spin-on element of 5 bar [72.5 psi]	S00
----	---	-----

#### Bypass valve

05	<b>Without</b> bypass valve	0
	<b>With</b> bypass valve – release pressure 2.0 bar [29.0 psi]	4
	<b>With</b> bypass valve – release pressure 2.5 bar [36.3 psi]	5

#### Seal

06	NBR seal	M
	FKM seal	V

#### Order example:

**82.45 H10XL-S00-0-M**

**Material no.: R928019444**

## Preferred types

### Spin-on element type 80, NBR seal

Type	Material no. Spin-on element, filter rating in $\mu\text{m}$	
	H10XL	P10
80.30/20 ...-S00-0-M	R928054793	R928054792
80.45/20 ...-S00-0-M	R928019736	R928022583
80.45/21 ...-S00-0-M	R928016611	R928016609
80.60/20 ...-S00-0-M	R928019738	R928038378
80.60/21 ...-S00-0-M	R928018950	R928018951
80.90 ...-S00-0-M	R928016614	R928016612
80,130 ...-S00-0-M	R928016617	R928016615

### Spin-on element type 81, NBR seal

Type	Material no. Spin-on element, filter rating in $\mu\text{m}$	
	H10XL	P10
81.90 ...-S00-0-M	R928035941	R928025526
81,130 ...-S00-0-M	R928035943	R928025391

### Spin-on element type 82, NBR seal

Type	Material no. Spin-on element, filter rating in $\mu\text{m}$	
	H10XL	P10
82.30 ...-S00-0-M	R928038865	R928046556
82.45 ...-S00-0-M	R928019444	R928025436
82.50 ...-S00-0-M	R928046564	R928046566
82.60 ...-S00-0-M	R928019719	R928046571
82.80 ...-S00-0-M	R928054791	R928054790

## Assignment of spin-on elements to filter series

Spin-on element (type)	Series	Application	Data sheet no. <sup>1)</sup>
80	7 SL	Spin-on filter	51426
Spin-on element (type)	Series	Application	Data sheet no. <sup>1)</sup>
81	7 SLS	Spin-on filter with check valve	51426
Spin-on element (type)	Series	Application	Data sheet no. <sup>1)</sup>
82	50 SL	Spin-on filter	51476

<sup>1)</sup> For further information, please refer to the respective data sheet

## Filter design

Easy selection of the filter size is made possible by the FilterSelect online tool. The filter can be designed using the operating pressure, flow and fluid system parameters. The required filter rating is based on the application, the sensitivity to contamination of the components and the environmental conditions.

The program leads you through the menu on a step-by-step basis.

A documentation of the filter selection can finally be created in the form of a PDF file. This file contains the entered parameters, the designed filter with material number including spare parts, and the pressure loss curves.

Link FilterSelect:

<http://filtersselect.boschrexroth.com/rexfilter/>

Other languages can be selected using the page navigation.

Home Language About us Legal notice www.bosch.com

**Rexroth**  
Bosch Group

www.boschrexroth.com

Contact

Bosch Rexroth FilterSelect

**standard search**

application: hydraulics for industrial use and applications with lubricating oil

Product category: please select

type: please select

pressure range: please select

filter material: please select

fineness: please select

volume flow rate: [ ] [l/min]

viscosity:  
\* = working point

kin viscosity 1: 32 [mm<sup>2</sup>/s]

search via type of medium full-text search medium

please select

please select

temp 1: [ ] [°C] [ ] [°F] kin viscosity 1: [ ] [mm<sup>2</sup>/s]

dyn. Viscosity 1: [ ] [cP] density 1: [ ] [kg/dm<sup>3</sup>] kin viscosity 1: [ ] [mm<sup>2</sup>/s]

collapse pressure resistance according to ISO 2941: 30 bar

Start search

## Function, cross-section

### 80 and 81 Spin-on elements

Essentially, the spin-on element consists of a filter bowl (1), a filter element (2), a seal (3), a threaded mounting plate (4) incl. connection thread and an optional bypass valve (5). Operating pressure max. 7 bar [101.5 psi].

The actual filtration process takes part in the filter element. The main filter variables, such as retention capacity, dirt holding capacity and pressure loss, are determined by the filter elements and the filter media used to construct them. The flow is generally from outside to inside.

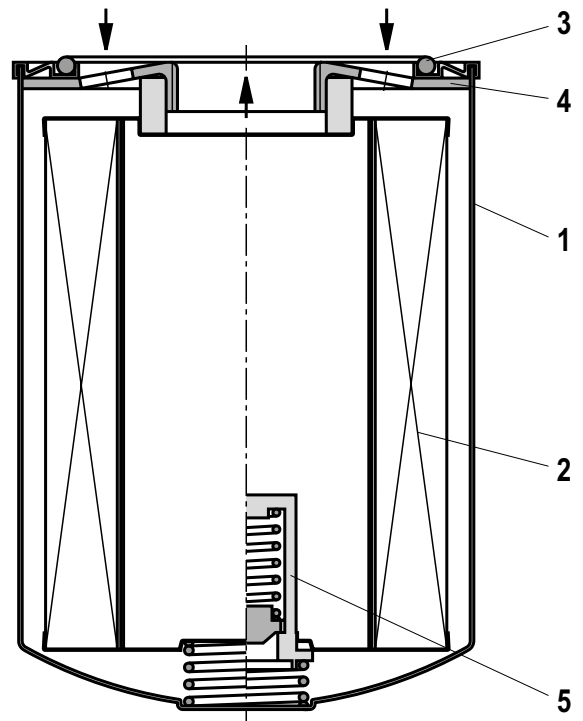

Spin-on element 80 / 81

### 82 Spin-on elements

Essentially, the spin-on element consists of a filter bowl (1), a filter element (2), a seal (3), a threaded mounting piece (4) incl. connection thread and an optional bypass valve (5). Operating pressure max. 40 bar [580 psi].

The actual filtration process takes part in the filter element. The main filter variables, such as retention capacity, dirt holding capacity and pressure loss, are determined by the filter elements and the filter media used to construct them. The flow is generally from outside to inside.

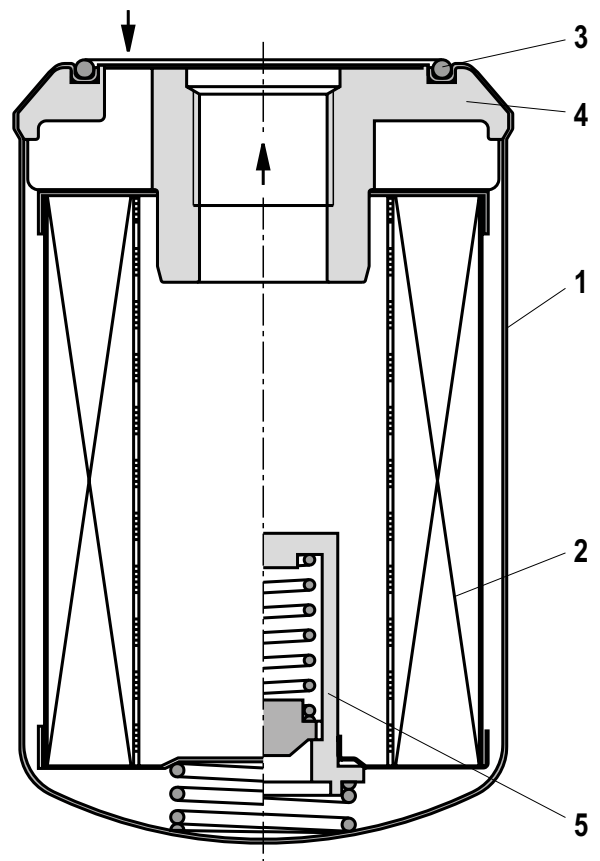

Spin-on element 82

## Filter variables

### Filter rating and attainable oil cleanliness

The main goal when using industrial filters is not only the direct protection of machine components but to attain the required oil cleanliness. Oil cleanliness is defined on the

basis of oil cleanliness classes which classify how the amount of particles of the existing contamination is distributed in the operating liquid.

### Filtration performance

#### Filtration ratio $\beta_{x(c)}$ ( $\beta$ value)

The retention capacity of hydraulic filters against contamination in a hydraulic system is characterized by the filtration ratio  $\beta_{x(c)}$ . This variable is the most important performance characteristic of a hydraulic filter. It is measured in the multipass test, and is the average value of the specified initial and final pressure differential according to ISO 16889 using ISOMTD test dust.

The filtration ratio  $\beta_{x(c)}$  is defined as the ratio of the particle count of the respective particle size on both sides of the filter.

#### Dirt holding capacity

It is also measured using the multipass test and determines the amount of test dust ISOMTD which is fed to the filter medium until a specified pressure differential increase has been reached.

#### Pressure loss (also pressure differential or delta p)

The pressure loss of the spin-on element is the relevant characteristic value for the determination of the filter size. Here it concerns the filter manufacturer's recommendations or the filter user's specifications. This characteristic value depends on many factors. These are mainly: the rating of the filter medium, its geometry and arrangement in the filter element, the filter area, the operating viscosity of the fluid and the flow.

The term "delta p" is often also expressed with the symbol: " $\Delta p$ ".

When sizing the complete filter with a spin-on element, an initial pressure loss is determined which must not be exceeded by the new spin-on element based on the aforementioned conditions.

The following diagram shows the typical pressure loss behavior of spin-on elements with different material ratings at different flow rates.

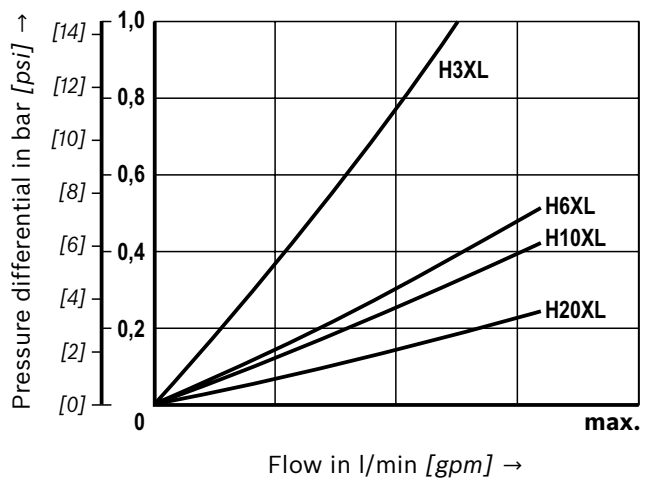



## Filter variables

### Overview

For the separation of particles different filter media in various ratings are used according to application and requirement.

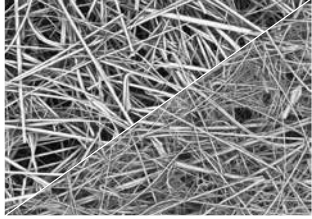
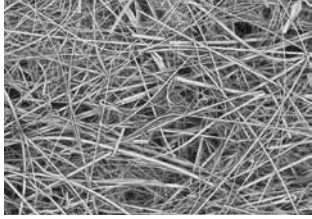
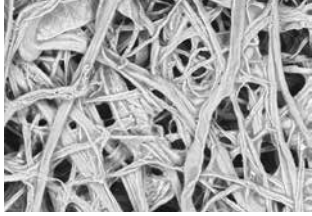
Filter medium/set-up	electron microscope image
<p><b>H...XL, Glass fiber material</b> Depth filter, combination of inorganic micro glass filter medium. High dirt holding capacity due to multi-layer technology.</p>	
<p><b>H..., glass fiber material</b> Depth filter, combination of inorganic micro glass filter medium. Single-layer constructed variant of H... XL.</p>	
<p><b>P..., Filter paper</b> Inexpensive depth filter made of filter paper with supporting tissue. Made of specially coated cellulose fiber preventing humidity and swelling.</p>	

**Technical data preferred program**

(for applications outside these parameters, please consult us!)

<b>General</b>						
Ambient temperature range	°C [°F]	-40 ... +65 [-40 ... +149]				
Storage conditions	▶ NBR seal	°C [°F]	-40 ... +65 [-40 ... +149]; max. relative air humidity: 65%			
	▶ FKM seal	°C [°F]	-20 ... +65 [-4 ... +149]; max. relative air humidity: 65%			
Weight 80 Spin-on elements <sup>1)</sup>	Size	<b>30/20</b>	<b>45/20</b>	<b>45/21</b>	<b>60/20</b>	
	kg	0.7	0.7	0.7	1.0	
	[lbs]	[1.5]	[1.5]	[1.5]	[2.2]	
	Size	<b>60/21</b>	<b>90</b>	<b>130</b>		
	kg	1.1	1.3	1.5		
	[lbs]	[2.5]	[2.9]	[32.0]		
Weight 81 Spin-on elements <sup>1)</sup>	Size	<b>90</b>		<b>130</b>		
	kg	1.4		1.5		
	[lbs]	[3.09]		[3.31]		
Weight 82 Spin-on elements <sup>1)</sup>	Size	<b>30 (D)</b>	<b>45 (D)</b>	<b>50 (D)</b>	<b>60 (D)</b>	<b>80 (D)</b>
	kg	0.7	0.7	0.7	1.0	1.1
	[lbs]	[1.5]	[1.5]	[1.5]	[2.2]	[2.5]
Material 80 and 81 Spin-on elements	▶ Threaded mounting plate	Galvanized steel				
	▶ Filter element base/cover	Tin-coated steel				
	▶ Support tube	Galvanized steel				
	▶ Filter bowl	Galvanized steel				
	▶ Seals	NBR or FKM				
Material 82 Spin-on elements	▶ Threaded mounting piece	Aluminum				
	▶ Filter element base/cover	Tin-coated steel				
	▶ Support tube	Galvanized steel				
	▶ Filter bowl	Galvanized steel				
	▶ Seals	NBR or FKM				
<b>Hydraulics</b>						
Max. operating pressure	▶ 80 and 81	bar [psi]	7 [101.5]			
	▶ 82	bar [psi]	40 [580] <sup>2)</sup>			
Hydraulic fluid temperature range	°C [°F]	-10 ... +100 [+14 ... +212]				
 <b>Note to cold start:</b>		-40 ... -10 [-40 ... +14] A reduction of pressure as well as flow rate, each a min. of 50% must be taken into account during a cold startup. A bypass valve is essential.				
Min. medium conductivity	pS/m	300				
Filtration direction		From the outside to the inside				
Fatigue strength as per ISO 10771	Load cycles	44,500 with max. operating pressure				

<sup>1)</sup> Weights are based on glass fiber material.<sup>2)</sup> Validation according to ISO 10779**Operating temperature range, depending on the material combination**

Material	Code letter	Operating temperature range °C [°F]
<b>Seal</b>		
NBR	M	-40 ... +100 [-40 ... +212]
FKM	V	-20 ... +210 [-4 ... +410]

**Compatibility with permitted hydraulic fluids**

Hydraulic fluid	Classification	Suitable sealing materials	Standards
Mineral oil	HLP	NBR	DIN 51524

**Important information on hydraulic fluids:**

For more information and data on the use of other hydraulic fluids, please refer to data sheet 90220 or contact us.

## Dimensions: Spin-on element 80 / 81, 82

(dimensions in mm [in])

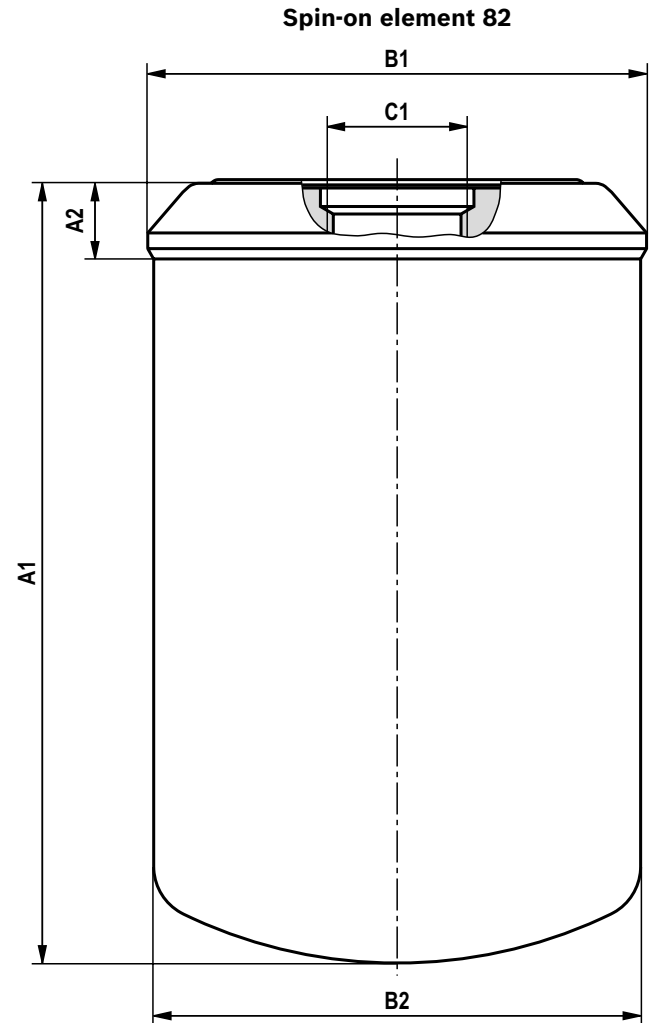
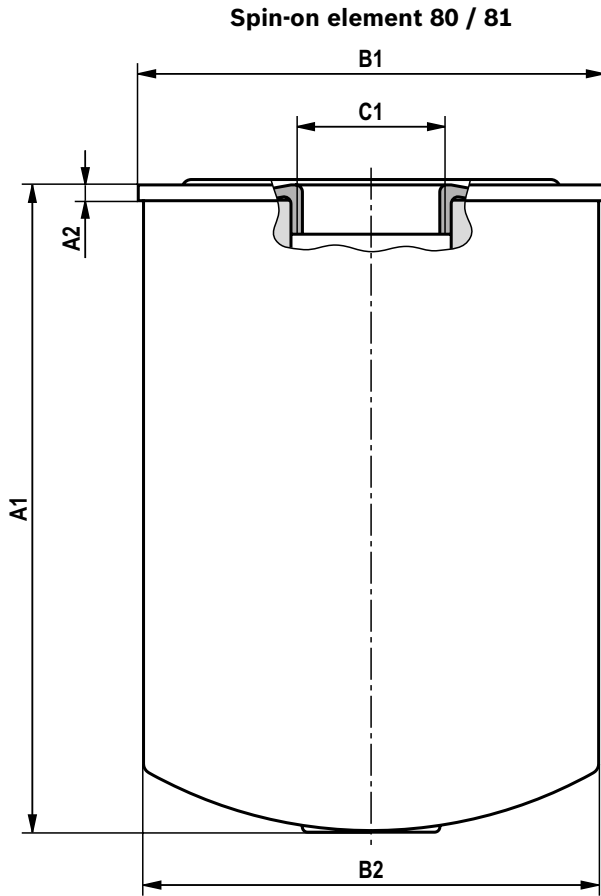

Type	A1	A2	ØB1	ØB2	C1
<b>80.30/20</b>	95 [3.74]	3 [0.12]	93 [3.66]	92 [3.62]	3/4"-16 UNF
<b>80.45/20</b>	145.5 [5.73]				3/4"-16 UNF
<b>80.45/21</b>					G3/4
<b>80.60/20</b>	205 [8.07]				1"-12 UNF
<b>80.60/21</b>					G3/4
<b>80.90</b>	182.5 [7.19]	4.5 [0.18]	129 [5.08]	128 [5.04]	G1 1/4
<b>80,130</b>	230.5 [9.07]				
<b>81.90</b>	182.5 [7.19]	4.5 [0.18]	129 [5.08]	128 [5.04]	M42x2
<b>81,130</b>	230.5 [9.07]				

Type	A1	A2	ØB1	ØB2	C1
<b>82.30</b>	110 [4.33]	14	94.3 [3.71]	92 [3.62]	1"-12 UNF
<b>82.30D</b>					1 3/8"-12 UN
<b>82.45</b>					1"-12 UNF
<b>82.45D</b>					1 3/8"-12 UN
<b>82.50</b>	172 [6.77]	14 [0.55]	94.3 [3.71]	92 [3.62]	1"-12 UNF
<b>82.50D</b>					1 3/8"-12 UN
<b>82.60</b>	212 [8.35]	14 [0.55]	94.3 [3.71]	92 [3.62]	1"-12 UNF
<b>82.60D</b>					1 3/8"-12 UN
<b>82.80</b>	237 [9.33]				1"-12 UNF
<b>82.80D</b>					1 3/8"-12 UN

**Installation station: Spin-on element 80 / 81**  
(dimensions in mm [*in*])

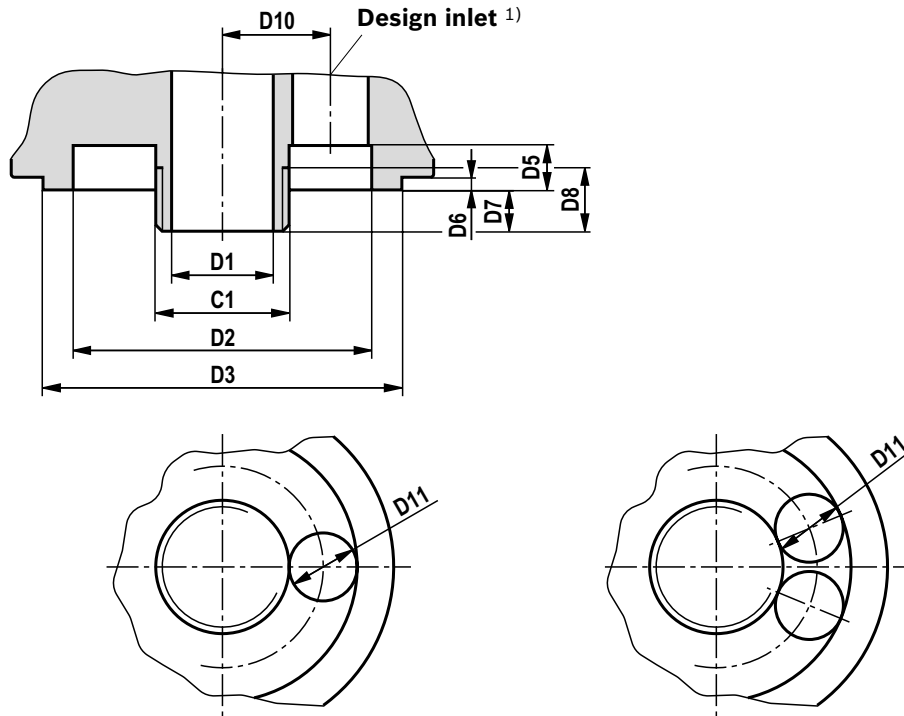

Type	C1	ØD1	ØD2	ØD3	D5	D6	D7	D8	D10	ØD11
<b>80.30/20</b>	3/4"-16 UNF	13 [0.51]	59 [2.32]	75 [2.95]	2 [0.08]	2 [0.08]	16 [0.63]	15.5 [0.61]	67 [2.64]	max. 8 [0.31]
<b>80.45/20</b>	3/4"-16 UNF									
<b>80.45/21</b>	G3/4									
<b>80.60/20</b>	1"-12 UNF									
<b>80.60/21</b>	G3/4									
<b>80.90</b>	G1 1/4	32 [1.26]	95 [3.74]	113 [4.45]	14 [0.55]	12 [0.47]	13 [0.51]	20 [0.79]	104 [4.09]	max. 9 [0.35]
<b>80,130</b>			94 [3.70]						103.5 [4.07]	
<b>81.90</b>	M42x2									
<b>81,130</b>										

1) Cross section inlet must correspond approx. to cross section inlet "E4", therefore, one or two holes with a maximum diameter of "D11" depending on the flow, flow velocity < 3 m/s in the inlet.

## Installation station: Spin-on element 82

(dimensions in mm [in])

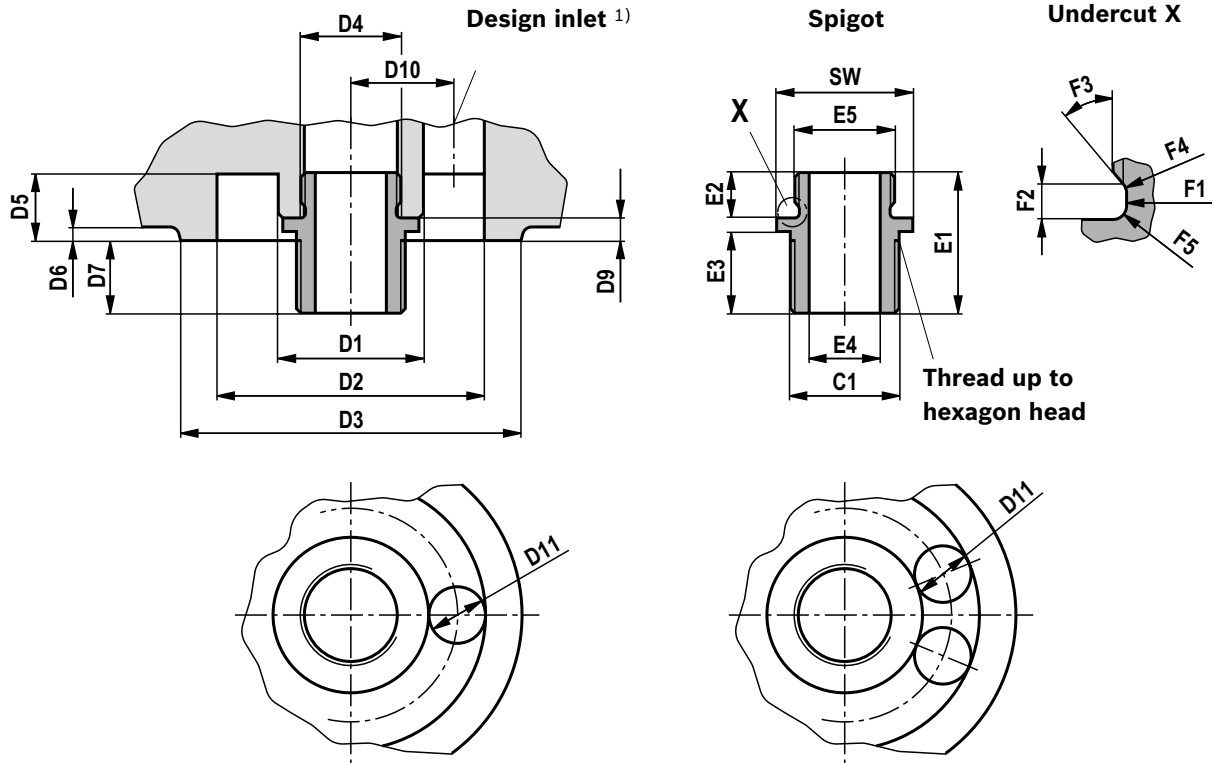

Type	ØD1	ØD2	ØD3	D4	D5	D6	D7	D9	D10	ØD11
82.30	34 [1.34]	59 [2.32]	75 [2.95]	M22x1.5	6.5 [0.26]	4 [0.16]	16 [0.63]	5 [0.20]	67 [2.64]	max. 8 [0.31]
82.30D										
82.45										
82.45D										
82.50										
82.50D										
82.60										
82.60D										
82.80										
82.80D										

Type	E1	E2	E3	ØE4	E5	SW	ØF1	F2	F3	F4	F5
82.30	31 [1.22]	10 [0.39]	18 [0.71]	16 [0.63]	M22x1.5	30 [1.18]	20 [0.79]	2.5 [0.10]	40°	R1	R1
82.30D	35 [1.38]		25 [0.98]								
82.45			18 [0.71]								
82.45D	25 [0.98]										
82.50											
82.50D	35 [1.38]										
82.60											
82.60D	35 [1.38]										
82.80											
82.80D	35 [1.38]										

<sup>1)</sup> Cross section inlet must correspond approx. to cross section outlet "E4", therefore, one or two holes with a maximum diameter of "D11" depending on the flow, provide flow velocity < 3 m/s in the inlet.

## Filter media

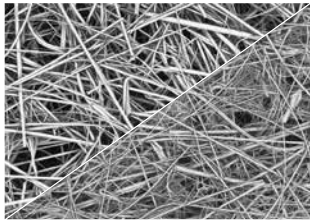
Technical data	H...XL
<p><b>Glass fiber material, H...XL</b></p> <p>The filter medium achieves the best possible degree of purity compared to other filter media. It is suitable for fluids such as hydraulic oils, lubricants, chemical and industrial liquids. Due to its designed retention capacity (ISO 16889), it offers therefore highly effective protection for machine and system components which are sensitive to contamination.</p> <ul style="list-style-type: none"> <li>▶ H...XL depth filter made of inorganic glass fiber material</li> <li>▶ Absolute filtration/defined retention capacity according to ISO 16889</li> <li>▶ High dirt holding capacity due to multi-layer set-up</li> <li>▶ Non-reusable filter (not cleanable due to the depth filtration effect)</li> </ul>	
<p><b>Filter rating and attainable oil cleanliness</b></p> <p>The following table provides recommendations for the selection of a filter medium in dependency of the application and indicates the average oil cleanliness class attainable according to ISO 4406 or SAE-AS 4059.</p>	

### glass fiber material

oil cleanliness class ISO 4406	to be achieved with filter			Hydraulic system	
	$\beta_{x(c)} = 200$	Material	Possible arrangement		
13/10/8 - 17/13/10	3 $\mu\text{m}$	Glass fiber material H...XL	Return flow filter or pressure filter		Servo valves
15/12/10 - 19/14/11	6 $\mu\text{m}$				High-response valves
17/14/10 - 21/16/13	10 $\mu\text{m}$				Proportional valves
19/16/12 - 22/17/14	20 $\mu\text{m}$				General pumps and valves

### Achievable filtration ratio $\beta_{x(c)}$ ( $\beta$ value)

Typical  $\beta$  values up to 2.2 bar [31.9 psi]  $\Delta p$  pressure increase at the filter element <sup>1)</sup>

Filter medium	Particle size "x" for different $\beta$ values, measurement according to ISO 16889		
	$\beta_{x(c)} \geq 75$	$\beta_{x(c)} \geq 200$	$\beta_{x(c)} \geq 1000$
<b>H3XL</b>	4.0 $\mu\text{m}(c)$	< 4.5 $\mu\text{m}(c)$	5.0 $\mu\text{m}(c)$
<b>H6XL</b>	4.8 $\mu\text{m}(c)$	5.5 $\mu\text{m}(c)$	7.5 $\mu\text{m}(c)$
<b>H10XL</b>	6.5 $\mu\text{m}(c)$	7.5 $\mu\text{m}(c)$	9.5 $\mu\text{m}(c)$
<b>H20XL</b>	18.5 $\mu\text{m}(c)$	20.0 $\mu\text{m}(c)$	22.0 $\mu\text{m}(c)$

<sup>1)</sup> Filtration ratio  $\beta_{x(c)}$  for other filter media upon request

**Filtration ratio  $\beta_{x(c)}$  as a function of the particle size  $\mu\text{m}(c)$**

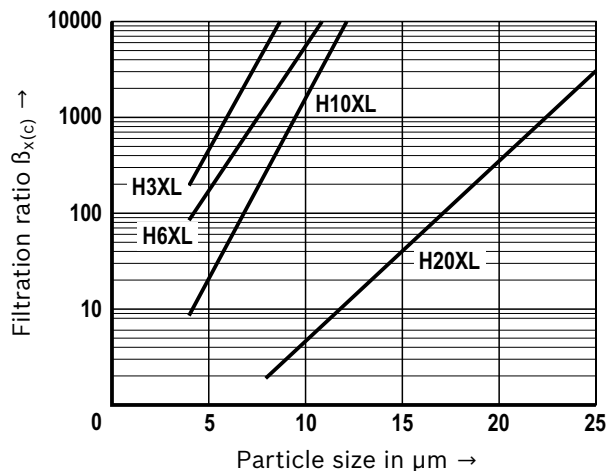

## Filter media

<b>Technical data</b>	<b>H...XL</b>
-----------------------	---------------

### Dirt holding capacity

Compared to conventional filter media with insertion technology, the filter material H...XL features a high dirt holding capacity because it is made of two separate filter layers connected in series.

**Conventional filter element**   
 (single-layer glass fiber material)  
**Rexroth H...XL filter element**   
 (multi-layer glass fiber material)

### Superior dirt holding capacity of H...XL filter elements

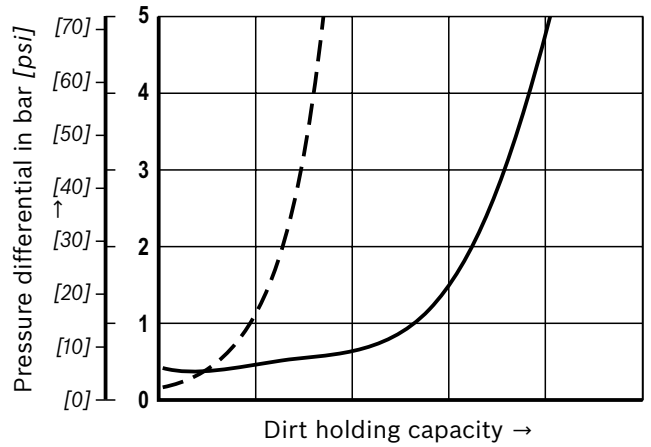

<b>Technical data</b>	<b>P...</b>
-----------------------	-------------

### Filter paper, P...

Filter paper is used for the filtration of lubricating oil and for pre-filtration. Filter paper has the following features:

- ▶ Depth filter made of cellulose fibers
- ▶ Specially coated to prevent swelling caused by humidity
- ▶ Pleated design, single, two or three-layer design
- ▶ Non-reusable filter (not cleanable due to the depth filtration effect)

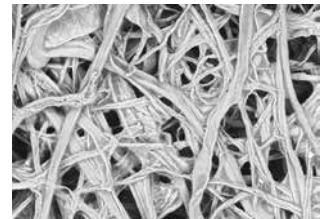

Filter medium	Nominal filter rating	Filtration ratio $\beta$ values <sup>1)</sup>	Retention rate at 10 $\mu\text{m}$ <sup>1)</sup>
<b>P10</b>	10 $\mu\text{m}$	$\beta_{10(c)} > 2.0$	50%
<b>P25</b>	25 $\mu\text{m}$	$\beta_{10(c)} > 1.25$	20%

<sup>1)</sup> in accordance with ISO 16889

### Filter paper

oil cleanliness class ISO 4406	to be achieved with filter			Hydraulic system
	$\beta_{x(c)} = 200$	Material	Possible arrangement	
20/19/14 - 22/20/15	10 $\mu\text{m}$	Paper P...	Return flow or pressure filters	----- For production facilities
21/20/15 - 22/21/16	25 $\mu\text{m}$			

## Assembly, commissioning, maintenance

### When should the spin-on element be replaced or cleaned?

As soon as the dynamic pressure or the pressure differential set on the maintenance indicator is reached, the red push button of the optical-mechanical maintenance indicator pops out. In addition an electrical signal is given if an electronic switching element is present.

If the filter does not have a maintenance indicator, we recommend exchanging the spin-on element at least every 6 months or a maximum of 1000 hours operation, as spin-on elements have no fatigue limit rating.

### Exchanging the spin-on element

- ▶ Switch off the system and discharge the filter on the pressure side.

Detailed instructions with regard to the exchange of spin-on elements can be found on the data sheet of the relevant filter series.

#### **Application notes:**

- ▶ The spin-on element housing is elastically deformed under dynamic stress.
- ▶ Spin-on elements have no fatigue limit rating.

#### **WARNING!**

- |   |   |
|---|---|
| ▶ Filters are containers under pressure. Before opening the filter housing, check whether the system pressure in the filter has been decreased to ambient pressure. | Only then may the filter housing be opened for maintenance. |
|---|---|

#### **Note:**

- ▶ From a cold start the preset optical maintenance indicator signal may be exceeded due to the high viscosity. After reaching the operating temperature, the mechanical optical display can be reset manually. The electrical signal will go out after the operating temperature has been reached.

- If the maintenance indicator is disregarded, the increasing pressure differential may damage the filter element (collapse).
- ▶ Warranty becomes void if the delivered item is changed by the ordering party or third parties or improperly mounted, installed, maintained, repaired, used or exposed to environmental condition that do not comply with the installation conditions.



## Directives and standardization

### Product validation

Rexroth filter elements are tested and quality-monitored according to different ISO test standards:

Filtration performance test (multipass test)	ISO 16889:2008-06
$\Delta p$ (pressure loss) characteristic curves	ISO 3968:2001-12
Compatibility with hydraulic fluid	ISO 2943:1998-11
Collapse pressure test	ISO 2941:2009-04
Fluid Technology; Hydraulic Filter – Part 2; Assessment Criteria and Requirements	DIN 24550-2:2006-09

The development, manufacture and assembly of Rexroth industrial filters and Rexroth filter elements is carried out within the framework of a certified quality management system in accordance with ISO 9001:2000.

### Environmental safety and recycling

- The used spin-on element should be disposed of in accordance with the respective country-specific legal regulations of environmental protection.

## Notes

Bosch Rexroth AG  
Ketsch plant  
Hardtwaldstr. 43  
68775 Ketsch, Germany  
Phone +49 (0) 62 02/603-0  
filter-support@boschrexroth.de  
www.boschrexroth.com

© This document, as well as the data, specifications and other information set forth in it, are the exclusive property of Bosch Rexroth AG. It may not be reproduced or given to third parties without the consent of Bosch Rexroth AG. The data specified above only serve to describe the product. It cannot be used to derive statements concerning a certain condition or suitability for a certain application. This information also does not release the user from exercising his/her own judgment and conducting his/her own testing. Our products are subject to a natural process of wear and aging.