

Proportional pressure reducing valve, direct operated

Type 3DREP ...XE

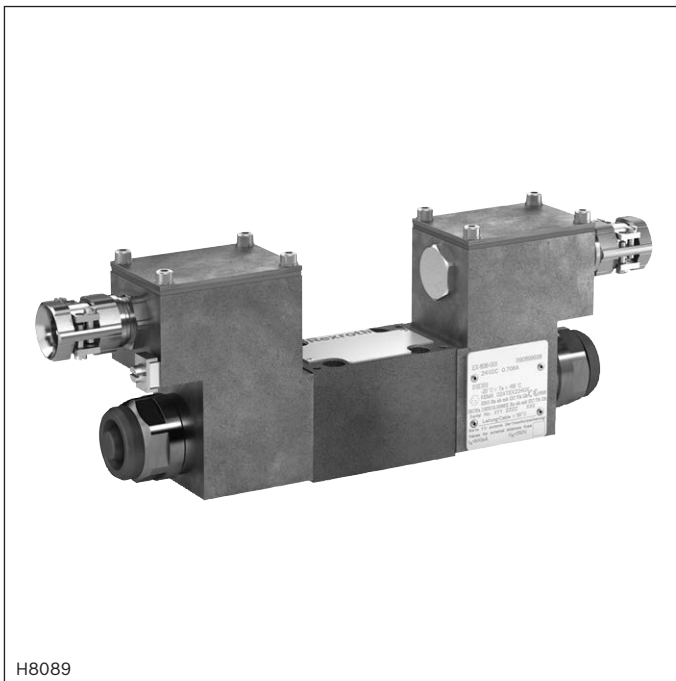

- ▶ Size 6
- ▶ Component series 2X
- ▶ Maximum operating pressure 100 bar
- ▶ Maximum flow 15 l/min



ATEX units

For potentially explosive atmospheres



Information on explosion protection:

- ▶ Area of application in accordance with the Explosion Protection Directive 2014/34/EU:
 - II 2G; II 2D**
- ▶ Type of protection valve:
 - Ex h IIC T4 Gb X according to EN 80079-36
 - Ex h IIIC T115°C Db X according to EN 80079-36
- ▶ Type of protection, solenoid coil:
 - Ex eb mb IIC T4 Gb according to EN 60079-7 / EN 60079-18
 - Ex tb IIIC T115°C Db according to EN 60079-31
- ▶ Solenoid coil certified according to IECEx

Features

- ▶ 3-way version
- ▶ For intended use in potentially explosive atmosphere
- ▶ For pressure control in ports A and B
- ▶ For subplate mounting
- ▶ Porting pattern according to ISO 4401-03-02-0-05 (however, without locating hole)
- ▶ Solenoid coil is rotatable by 90°
- ▶ Electrical connection as individual connection with cable gland

Contents

Features	1
Ordering code	2
Symbols	3
Function, section	4
Technical data	5 ... 7
Characteristic curves	8
Dimensions	9
Installation conditions	10
Electrical connection	11
Further information	12



Notice: The documentation version with which the product was supplied is valid.

Ordering code

01	02	03	04	05	06	07	08	09	10		
3DREP	6		- 2X	/		E	G24	XE	J	/	

01	Proportional pressure reducing valve, direct operated	3DREP
02	Size 6	6

Symbols (simplified)

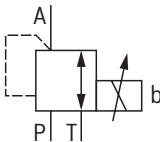
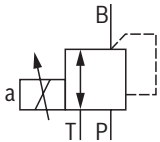
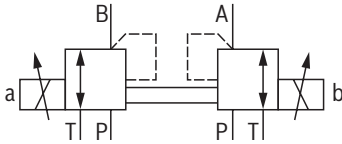
03		A
		B
		C

04	Component series 20 ... 29 (20 ... 29: unchanged installation and connection dimensions)	2X
05	Pressure rating 16 bar	16
	Pressure rating 25 bar	25
	Pressure rating 45 bar	45
06	Proportional solenoid	E

Supply voltage of the control electronics

07	Direct voltage 24 V	G24
----	---------------------	------------

Explosion protection

08	"Increased safety"	XE
	For details, see information on the explosion protection page 7	
09	Surface protection seawater-resistant, galvanized	J

Seal material (observe compatibility of seals with hydraulic fluid used, see page 6)

10	NBR seals	M
	FKM seals	V

Symbols (detailed)

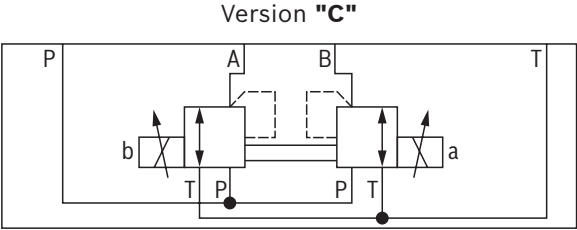
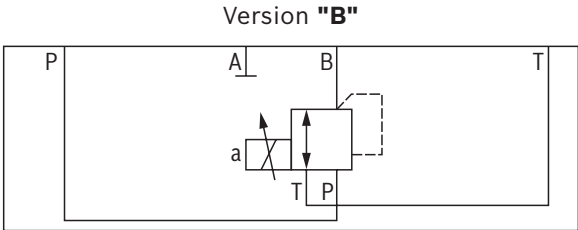
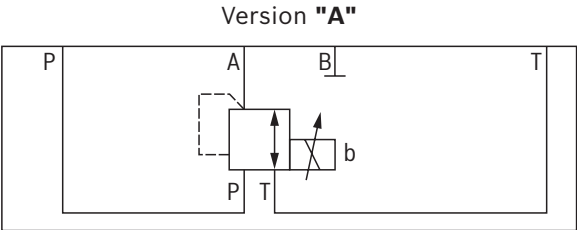

 **Notice:**
Representation according to DIN ISO 1219-1.

Function, section

Valves of type 3DREP are direct operated 3-way pressure reducing valves with proportional solenoids. They convert an electrical input signal into a proportional pressure output signal.

The proportional solenoids are controllable wet-pin DC solenoids. The solenoids are actuated by external control electronics.

Set-up

The valve basically consists of:

- ▶ Housing (1) with connection surface
- ▶ Control spool (2) with pressure measuring pins (3 and 4)
- ▶ Solenoids (5 and 6) with central thread

Function

The pressure in A or B is set by means of the proportional solenoids. The amount of the pressure depends on the current.

With de-energized solenoids (5, 6), the control spool (2) is held in the central position by means of the compression springs (8). Ports A and B are connected with T so that the hydraulic fluid can flow off to the tank without obstructions. When one proportional solenoid is actuated, e.g. solenoid "b" (5), the pressure measuring pin and the control spool (2) are moved to the left. This opens the connection from P to A and B to T via orifice-type cross-sections with progressive flow characteristic. With the surface of the pressure measuring pin (3), the pressure that builds up in channel A acts on the control

spool (2) and against the solenoid force. The pressure measuring pin (3) is supported by the solenoid "a". If the pressure exceeds the value set at solenoid "b", the control spool (2) is pushed back against the solenoid force and connects A to T until the set pressure is achieved again. The pressure is proportional to the solenoid current. When the solenoid is switched off, the control spool (2) is returned into the central position by the compression springs (8).

Notice:

Regarding valves of the version "3DREP 6 C", only one solenoid may be actuated at a time.

Valve with two spool positions (Version "A" and "B")

The function of this valve version basically corresponds to the valve with three spool positions. This 2-spool position valve is, however, only equipped with solenoid "a" (6) or solenoid "b" (5). Instead of the second proportional solenoid, there is a plug screw (7).

Notice:

The tank line must not be allowed to run empty. With corresponding installation conditions, a preload valve (preload pressure approx. 2 bar) must be installed.

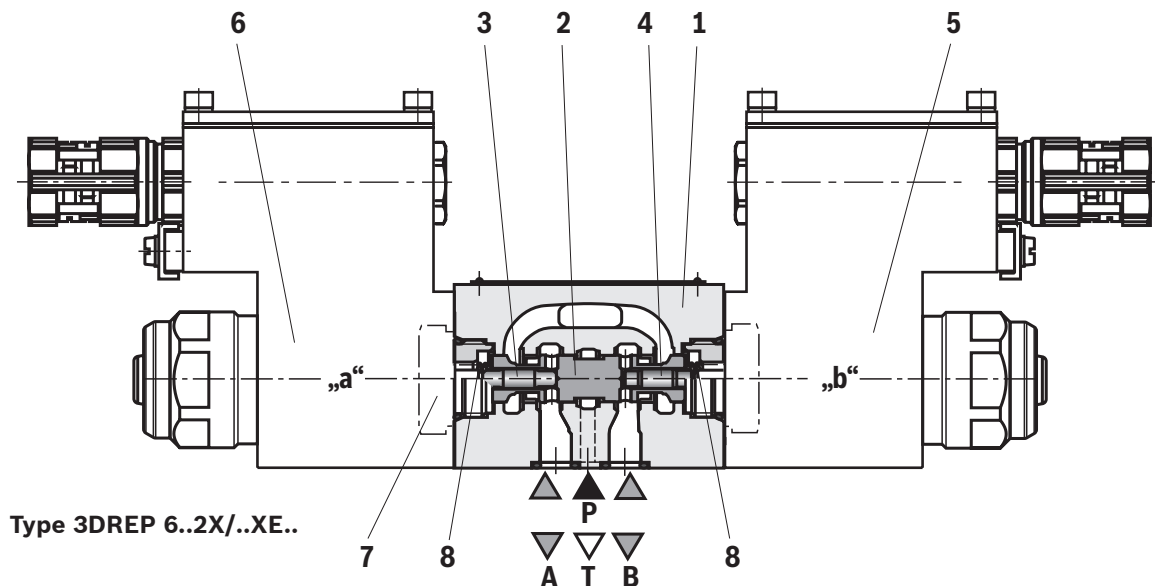

Technical data

(for applications outside these values, please consult us!)

General		
Installation position	any; preferably horizontal	
Storage temperature range	°C +5 ... +40	
Maximum storage time	Years 1	
Ambient temperature range	°C -20 ... +60	
Weight	▶ Version "A", "B"	kg 2.7
	▶ Version "C"	kg 4.4
Surface protection	galvanized	
Maximum surface temperature	°C See information on explosion protection, page 7	

Hydraulic		
Operating pressure range	▶ Port P	
	– Version "16"	bar 20 ... 100
	– Version "25"	bar 30 ... 100
	– Version "45"	bar 50 ... 100
	▶ Port T	bar 0 ... 30
Maximum flow P → A or P → B	l/min	15 ($\Delta p = 50$ bar) see characteristic curves page 8
Hydraulic fluid		See table page 6
Hydraulic fluid temperature range	°C	-20 ... +80 (NBR seals) -15 ... +80 (FKM seals)
Viscosity range	mm ² /s	20 ... 380 (preferably 30 ... 46)
Maximum admissible degree of contamination of the hydraulic fluid, cleanliness class according to ISO 4406 (c)		Class 17/15/12 ¹⁾
Hysteresis	%	≤ 6
Repetition accuracy	%	≤ 2
Response sensitivity	%	≤ 1
Range of inversion	%	≤ 2

¹⁾ The cleanliness classes specified for the components must be adhered to in hydraulic systems. Effective filtration prevents faults and simultaneously increases the life cycle of the components.

Available filters can be found at www.boschrexroth.com/filter.

Technical data

(for applications outside these values, please consult us!)

Hydraulic fluid	Classification	Suitable sealing materials	Standards	Data sheet
Mineral oils	HL, HLP, HLPD, HVLP, HVLPD	NBR, FKM	DIN 51524	90220
Bio-degradable	▶ Insoluble in water	HETG	ISO 15380	90221
		HEES		
	▶ Soluble in water	HEPG	ISO 15380	
Flame-resistant	▶ Water-free	HFDU (glycol base)	ISO 12922	90222
		HFDU (ester base)		
		HFDR		
	▶ Containing water	HFC (Fuchs: Hydrotherm 46M, Renosafe 500; Petrofer: Ultra Safe 620; Houghton: Safe 620; Union: Carbide HP5046)	ISO 12922	90223

**Important information on hydraulic fluids:**

- ▶ For further information and data on the use of other hydraulic fluids, please refer to the data sheets above or contact us.
- ▶ There may be limitations regarding the technical valve data (temperature, pressure range, life cycle, maintenance intervals, etc.).
- ▶ The ignition temperature of the hydraulic fluid used must be 50 K higher than the maximum surface temperature.
- ▶ **Bio-degradable and flame-resistant – containing water:**
If components with galvanic zinc coating (e.g. version "J3" or "J5") or parts containing zinc are used, small amounts of dissolved zinc may get into the hydraulic system and cause accelerated aging of the hydraulic fluid. Zinc soap may form as a chemical reaction product, which may clog filters, nozzles and solenoid valves – particularly in connection with local heat input.

▶ Flame-resistant – containing water:

- Due to increased cavitation tendency with HFC hydraulic fluids, the life cycle of the component may be reduced by up to 30% as compared to the use with mineral oil HLP. In order to reduce the cavitation effect, it is recommended – if possible specific to the installation – to back up the return flow pressure in ports T to approx. 20% of the pressure differential at the component.
- Dependent on the hydraulic fluid used, the maximum ambient and hydraulic fluid temperature must not exceed 50 °C. In order to reduce the heat input into the component, the command value profile is to be adjusted for proportional and high-response valves.

Technical data

(for applications outside these values, please consult us!)

electric	
Voltage type	Direct current or pulse-width modulated signal with a pulse voltage ≤ 28 V and a frequency ≥ 160 Hz up to max. 500 Hz
Type of signal	analog
Maximum solenoid current	A 1.03
Duty cycle	% 100

Control electronics ²⁾	
Valve amplifier for proportional valves without electrical position feedback; maximum current limitation 1 A	VT-MSPA2-2X/A5/1A0/000 according to data sheet 30232-01
Module for monitoring and limiting the solenoid currents with proportional valves	VT-MUXA2-2-1X/V0/1A according to data sheet 30290

Information on explosion protection		
Area of application according to Directive 2014/34/EU	II 2G	II 2D
Type of protection of valve according to EN 80079-36 ³⁾	Ex h IIC T4 Gb X	Ex h IIIC T115°C Db X
Maximum surface temperature ⁴⁾	°C 115	
Temperature class	T4	–
Type of protection, solenoid coil according to EN 60079-7 / EN 60079-18 / EN 60079-31	Ex eb mb IIC T4 Gb	Ex tb IIIC T115°C Db
Type examination certificate, solenoid coil	BVS 20 ATEX E 009 X	
"IECEx Certificate of Conformity" for solenoid coil	IECEx BVS 20.0007X	

²⁾ A monitoring circuit is to be provided for the monitoring of the solenoid current. We recommend operating the valves with the assemblies described herein. The valve amplifier and the monitoring module may only be installed outside the potentially explosive atmosphere.

³⁾ Ex h: structural safety c according to EN 80079-37.

⁴⁾ Surface temperature > 50 °C, provide contact protection.

 **Special application conditions for safe application:**

- ▶ In case of bank assembly, only one solenoid of all valves may be energized at a time.
- ▶ In case of valves with two solenoids, maximally one of the solenoids may be energized at a time.
- ▶ Only direct current or a pulse-width modulated signal with a pulse voltage ≤ 28 V and a frequency ≥ 160 Hz ... max. 500 Hz may be used for operation.
- ▶ Connection lines must be passed in a strain-relieved way. The first mounting point must be within 150 mm of the cable and line entry.
- ▶ The maximum temperature of the surface of the valve jacket is 115 °C. This has to be considered when selecting the connection cable and/or contact of the connection cable with the surface of the jacket is to be prevented.

Characteristic curves

(measured with HLP46, $\vartheta_{oil} = 40 \pm 5 \text{ }^\circ\text{C}$ and $p = 100 \text{ bar}$)

Nominal pressure dependent on the solenoid current

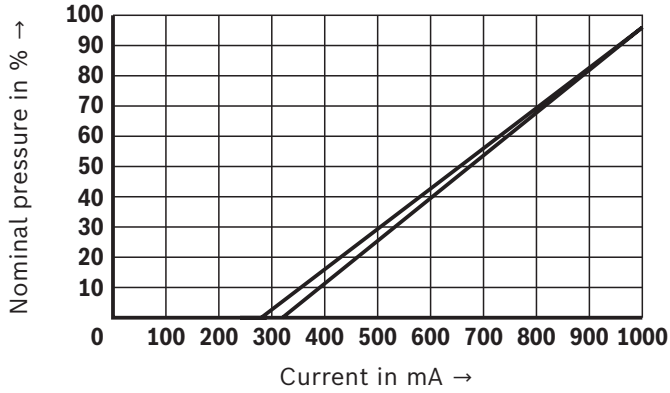

Δp - q_v characteristic curve

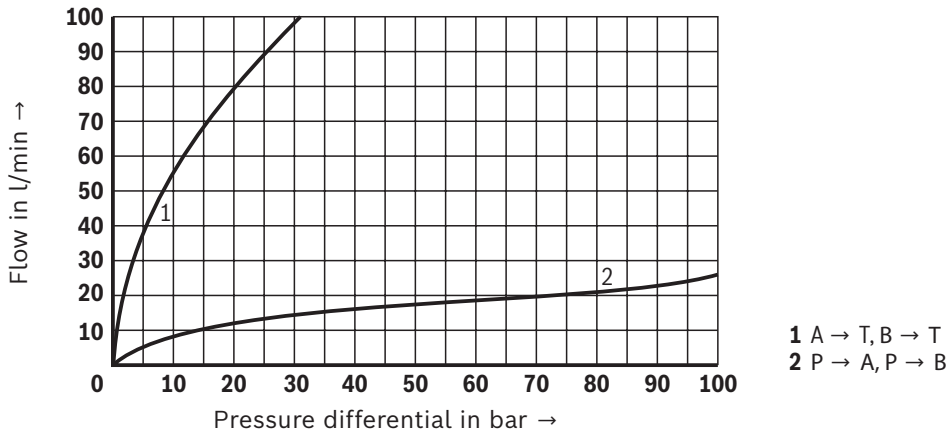

Pressure as a function of flow

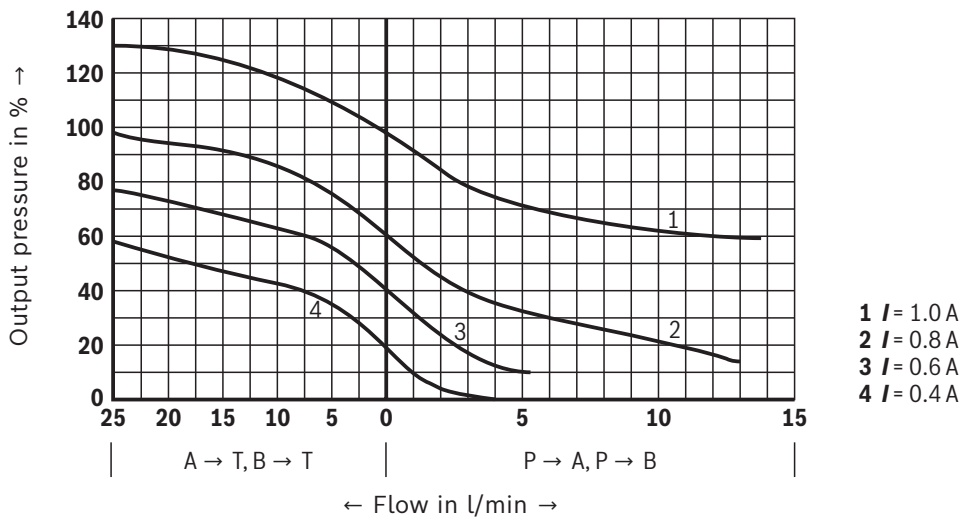

Dimensions

(dimensions in mm)

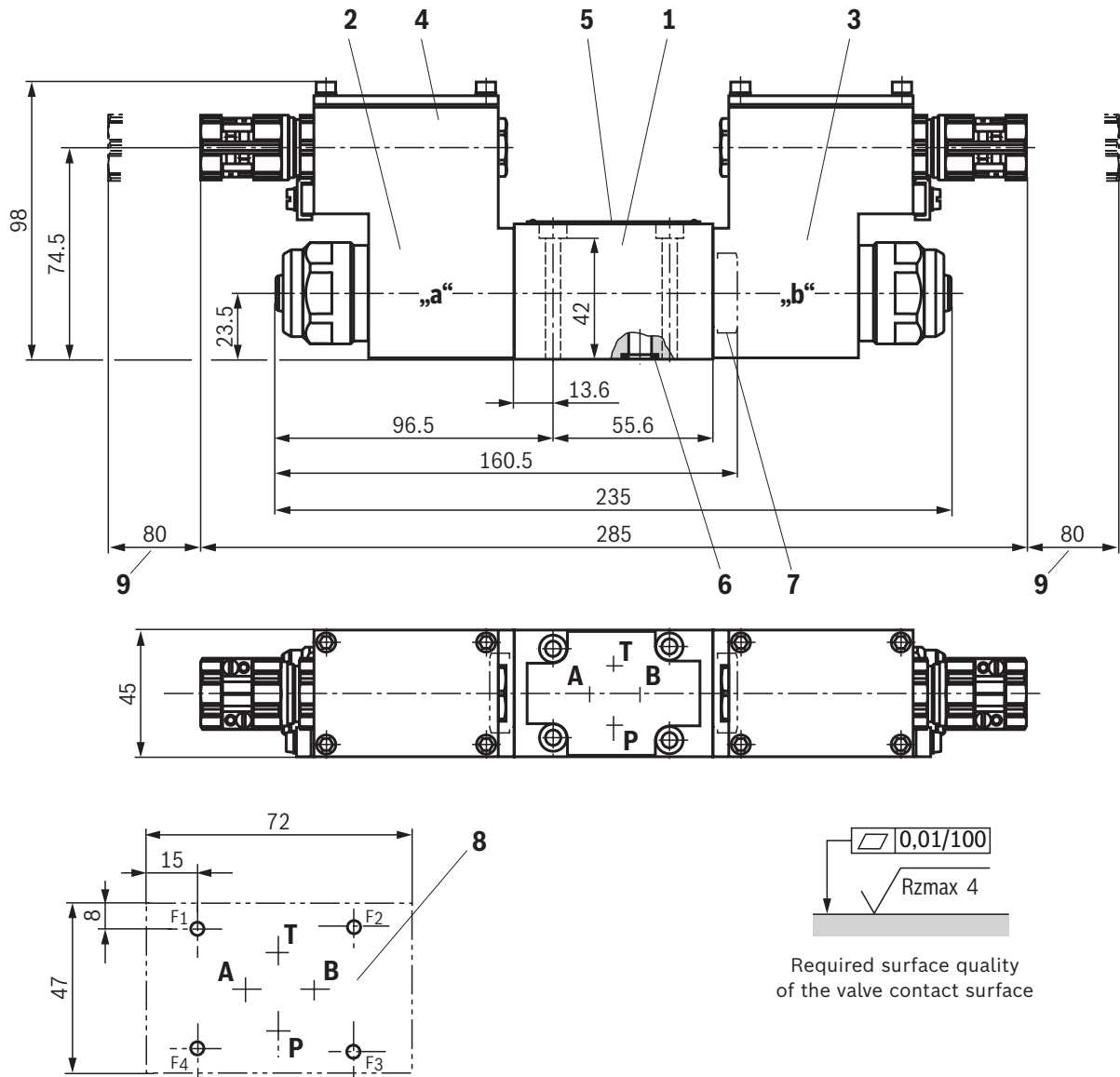

- 1 Valve housing
- 2 Proportional solenoid "a"
- 3 Proportional solenoid "b"
- 4 Terminal box
- 5 Name plate
- 6 identical seal rings for A, B, P and T
- 7 Plug screw for valve with one solenoid (2 spool positions, version A or B)
- 8 Porting pattern according to ISO 4401-03-02-0-05 (however, without locating hole)
- 9 Space required to remove the solenoid coil

Subplates (separate order) with porting pattern according to ISO 4401-03-02-0-05, see data sheet 45100.

Valve mounting screws (separate order)

Only use valve mounting screws with the subsequently listed thread diameters and strength properties:

4 hexagon socket head cap screws

ISO 4762 - M5 x 50 - 10.9

(Friction coefficient $\mu_{total} = 0.09 \dots 0.14$)

Tightening torque $M_A = 7 \text{ Nm} \pm 10\%$,

Material no. **R913043758**

Notice:

Subplates are no components in the sense of Directive 2014/34/EU and can be used after the manufacturer of the overall system has conducted an assessment of the risk of ignition.

The "G...J3" versions are free from aluminum and/or free from magnesium and galvanized.

Notice:

The dimensions are nominal dimensions which are subject to tolerances.

Installation conditions

(dimensions in mm)

	Individual assembly	Bank assembly
Subplate dimensions	Minimum dimensions Length ≥ 64 , width ≥ 58 , height ≥ 25	Minimum cross-section height ≥ 60 , width ≥ 85
Thermal conductivity of the subplate	≥ 36.2 W/mK	
Minimum distance between the longitudinal valve axes	≥ 55	

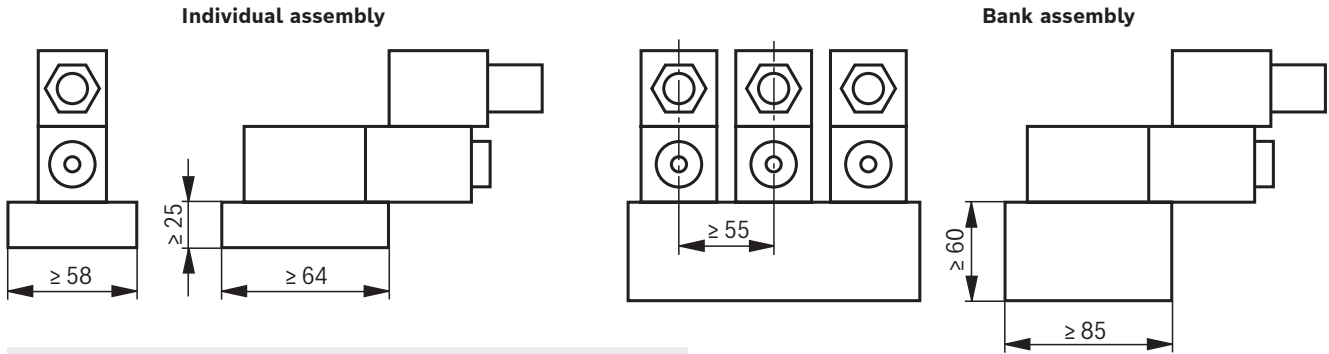

Notice:

Observe the "Special application conditions for safe application" on page 7.

Electrical connection

The type-examination tested solenoid coil of the valve is equipped with a terminal box, a type-examination tested cable entry and a type-examination tested blind plug. The connection is polarity-independent.

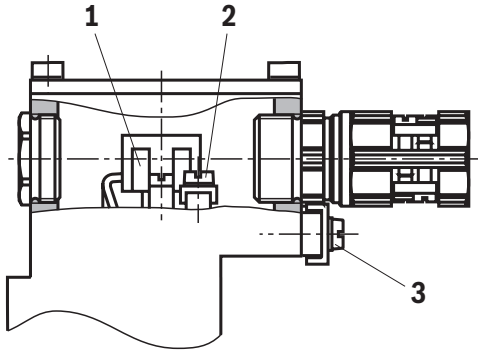

Notice:

When establishing the electrical connection, the protective grounding conductor (PE \perp) has to be connected properly.

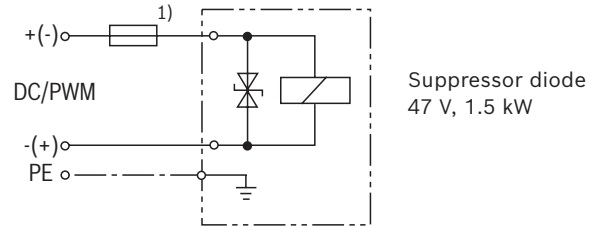

¹⁾ Recommended pre-fuse characteristics medium time-lag according to DIN 41571, 1.25 A.

Properties of the connection terminals and mounting elements

Position	Function	Connectable line cross-section
1	Operating voltage connection	single-wire 0.75 ... 2.5 mm ² finely stranded 0.75 ... 1.5 mm ²
2	Connection for protective grounding conductor	single-wire max. 2.5 mm ² finely stranded max. 1.5 mm ²
3	Connection for potential equalization conductor	single-wire max. 6 mm ² finely stranded max. 4 mm ²

Connection line	
Line type	non-armored and non-shielded connection lines
Temperature rating	°C ≤-20 ... ≥+110
Line diameter	mm 7 ... 10.5



Notice:

Only use finely stranded conductors if they have pressed-on wire end ferrules.

Over-current fuse and switch-off voltage peaks

Voltage data in the valve type code	Nominal voltage of solenoid coil	Rated current Solenoid coil	Rated current external miniature fuse: Medium time-lag (M) according to DIN 41571 and EN/IEC 60127	Rated voltage, external miniature fuse: Medium time-lag (M) according to DIN 41571 and EN/IEC 60127	Maximum voltage value when switching off	Interference protection circuit
G24	24 VDC	1.03 ADC	1.25 A	250 V	-70 V	Suppressor diode bi-directional

 **Notice:**

A fuse which corresponds to the rated current according to DIN 41571 and EN/IEC 60127 has to be connected upstream of every solenoid coil (max. $3 \times I_{\text{rated}}$).

The shut-off threshold of the fuse has to match the prospective short-circuit current of the supply source.

The prospective short-circuit current of the supply source may amount to a maximum of 1500 A.

This fuse may only be installed outside the potentially explosive atmospheres or must be of an explosion-proof design. When inductivities are switched off, voltage peaks result which may cause faults in the connected control electronics. For this reason, the solenoid coils comprise an interference protection circuit which dampens this voltage peak to the voltage value shown in the table.

Further information

- ▶ Subplates
- ▶ Hydraulic fluids on mineral oil basis
- ▶ Environmentally compatible hydraulic fluids
- ▶ Flame-resistant, water-free hydraulic fluids
- ▶ Flame-resistant hydraulic fluids - containing water (HFAE, HFAS, HFB, HFC)
- ▶ Use of non-electrical hydraulic components in an explosive environment (ATEX)
- ▶ Selection of filters
- ▶ Information on available spare parts

Data sheet 45100

Data sheet 90220

Data sheet 90221

Data sheet 90222

Data sheet 90223

Data sheet 07011

www.boschrexroth.com/filterwww.boschrexroth.com/spc

Bosch Rexroth AG
 Industrial Hydraulics
 Zum Eisengießer 1
 97816 Lohr am Main, Germany
 Phone +49 (0) 93 52/40 30 20
my.support@boschrexroth.de
www.boschrexroth.de

© All rights reserved to Bosch Rexroth AG, also regarding any disposal, exploitation, reproduction, editing, distribution, as well as in the event of applications for industrial property rights.
 The data specified above only serve to describe the product. No statements concerning a certain condition or suitability for a certain application can be derived from our information. The information given does not release the user from the obligation of own judgment and verification.
 It must be remembered that our products are subject to a natural process of wear and aging.