

Proportional pressure relief valve, direct operated

Type DBET...XE

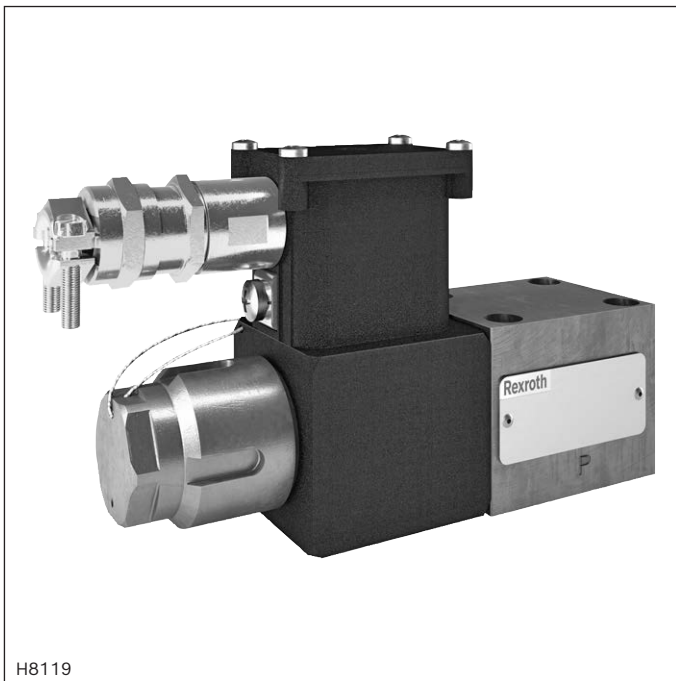

- ▶ Size 6
- ▶ Component series 6X
- ▶ Maximum operating pressure 420 bar
- ▶ Maximum flow 2 l/min



ATEX units For potentially explosive atmospheres



Information on explosion protection:

- ▶ Area of application in accordance with the Explosion Protection Directive 2014/34/EU:
II 2G, II 2D
- ▶ Type of protection valve:
 - Ex h IIC T4 Gb X according to EN 80079-36
 - Ex h IIIC T130°C Db X according to EN 80079-36
- ▶ Type of protection valve solenoid:
 - Gas: eb (EN 60079-7), mb (EN 60079-18)
 - Dust: tb (EN 60079-31)
- ▶ IECEx certificate of conformity of the valve solenoid

Features

- ▶ For intended use in potentially explosive atmospheres
- ▶ For subplate mounting
- ▶ Porting pattern according to ISO 4401-03-02-0-05
- ▶ Wet-pin DC solenoid
- ▶ Electrical connection as individual connection with cable gland
- ▶ The external metal parts are galvanized to protect them against corrosion (seawater-resistant)

Contents

Features	1
Contents	1
Ordering code	2
Symbols	2
Function, section	3
Technical data	4, 5
Characteristic curves	6, 7
Dimensions	8
Installation conditions	9
Electrical connection	10
Over-current fuse and switch-off voltage peaks	11
Further information	11

 **Notice:** The documentation version with which the product was supplied is valid.

Ordering code

01	02	03	04	05	06	07	08	09
DBET	-	-	6X	/	G24	XE	J	V

01	Proportional pressure relief valve	DBET
----	------------------------------------	------

Solenoid position (facing the cable gland)

02	Position up	1
	Position to the right	2
	Position down	3
	Position to the left	4

03	Component series 60 ... 69 (60 ... 69: unchanged installation and connection dimensions)	6X
----	--	----

Maximum pressure rating

04	50 bar	50
	100 bar	100
	200 bar	200
	315 bar	315
	350 bar	350
	420 bar	420

05	Internal pilot oil return	no code
	External pilot oil return (Y internally connected to T)	Y

06	Direct voltage 24 V	G24
----	---------------------	-----

Explosion protection

07	"Increased safety"	XE
	For details, see information on explosion protection, page 5	

Surface protection

08	Seawater-resistant	J
----	--------------------	---

Seal material (observe compatibility of seals with hydraulic fluid used, see page 4)

09	FKM seals	V
----	-----------	---

Symbols

Internal pilot oil return

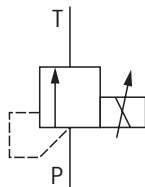

External pilot oil return

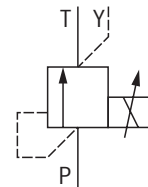

Function, section

General information

Proportional pressure relief valves of type DBET...XE are remote control valves in seat design and are intended for restricting the system pressure. Operation is effected by means of a proportional solenoid. The interior of the solenoid is connected to port T or Y and is filled with hydraulic fluid. Dependent on the electric command value, these valves can be used to steplessly set the system pressure to be limited.

The solenoid is controlled by an external amplifier of the type VT-MSPA2...1A0 (data sheet 30232-01). The maximum current at the solenoid must not exceed 1.0 A. In order to achieve this prescribed safety when operating the valve in the potentially explosive atmospheres, the solenoid current must be monitored and limited. This is to be ensured by means of the VT-MUXA2 safety module (data sheet 30290).

Set-up

The valve basically consists of:

- ▶ Housing with connection surface (1)
- ▶ Proportional solenoid (2)
- ▶ Valve seat (3)
- ▶ Valve poppet (4)
- ▶ Armature plunger (5)

Basic principle

For setting system pressure, a command value is specified at the control electronics. Dependent on the command value, the electronics actuate the solenoid coil with electric current. The proportional solenoid converts the electric current into mechanical force that acts on the valve poppet (4) via the armature plunger (5). The valve poppet (4) presses on the valve seat (3) and interrupts the connection between port P and T or Y. If the hydraulic force on the valve poppet (4) equals the solenoid force, the valve controls the set pressure by lifting the valve poppet (4) off the valve seat (3) and thus enabling hydraulic fluid to flow from port P to T or Y. With a command value of zero, only the minimum control current is applied to the proportional solenoid (2) and the minimum set pressure is set.

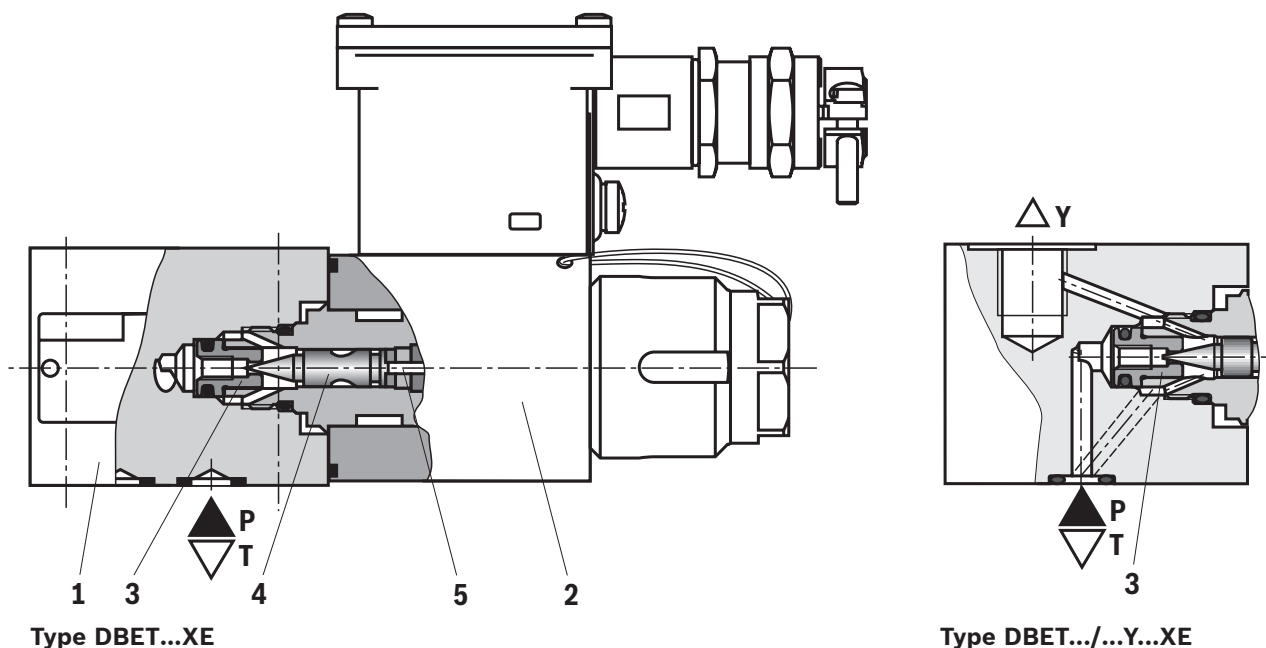

Technical data

(for applications outside these values, please consult us!)

General	
Installation position	any, preferably horizontal
Storage temperature range	°C 5 ... +40
Ambient temperature range	°C -20 ... +70
Weight	kg 2,7

Hydraulic			
Maximum operating pressure	▶ Port P	bar	420
Maximum set pressure at a command value of 10 V	▶ Pressure rating 50 bar	bar	52.5
	▶ Pressure rating 100 bar	bar	105
	▶ Pressure rating 200 bar	bar	210
	▶ Pressure rating 315 bar	bar	330
	▶ Pressure rating 350 bar	bar	370
	▶ Pressure rating 420 bar	bar	420
Minimum set pressure at a command value of 0		bar	see characteristic curves page 6
Return flow pressure	▶ Port T, Y	bar	0 (separate return line to tank)
Maximum operating pressure	▶ Blind counterbore A, B	bar	350
Maximum flow		l/min	see characteristic curves page 7 ¹⁾
Hydraulic fluid			see table below
Hydraulic fluid temperature range		°C	-15 ... +80 (preferably +40 ... +50)
Viscosity range		mm ² /s	20 ... 380 (preferably 30 ... 46)
Maximum admissible degree of contamination of the hydraulic fluid Cleanliness class according to ISO 4406 (c)			Class 20/18/15 ²⁾
Hysteresis		%	< 8 ³⁾
Range of inversion		%	< 0.5 ³⁾
Response sensitivity		%	< 0.5 ³⁾
Linearity		%	see characteristic curves page 7
Manufacturing tolerance of the command value pressure characteristic curve, related to 0.8 l/min; pressure increasing	▶ Command value 20%	%	< ±1.5 ^{3; 4)}
	▶ Command value 100%	%	< ±5 ^{3; 5)}
Step response ($T_u + T_g$) 0 → 100% and/or 100% → 0		ms	100 (depending on the system)
Line volume < 20 cm ³ ; $q_V = 0.8$ l/min			

Hydraulic fluid	Classification	Suitable sealing materials	Standards	Data sheet
Mineral oils	HL, HLP	FKM	DIN 51524	90220

**Important notice on hydraulic fluids:**

- ▶ For further information and data on the use of other hydraulic fluids, please refer to the data sheets above or contact us.
- ▶ There may be limitations regarding the technical valve data (temperature, pressure range, life cycle, maintenance intervals, etc.).

- ▶ The ignition temperature of the hydraulic fluid used must be 50 K higher than the maximum surface temperature.

- 1) If the maximum flow of the pressure rating is exceeded, a back pressure which exceeds the maximum nominal pressure of the valve may built up in port P.
- 2) The cleanliness classes specified for the components must be adhered to in hydraulic systems. Effective filtration prevents faults and simultaneously increases the life cycle of the components. Available filters can be found at www.boschrexroth.com/filter.

- 3) Of the maximum set pressure
- 4) Zero point calibration at the factory
- 5) Comparison at amplifier possible

Technical data

(for applications outside these values, please consult us!)

Electric		
Voltage type	Direct voltage; PWM signal 100 ... 500 Hz	
Type of signal	analog	
Maximum current	A 1.0	
Limiting power	W 13.5	
Solenoid coil resistance	▶ Cold value at 20 °C	Ω 8.3
	▶ Maximum hot value	Ω 12.56
Duty cycle	% 100	
Maximum coil temperature	°C 130	

Information on explosion protection		
Area of application according to Directive 2014/34/EU	II 2G, II 2D	
Type of protection of valve according to EN 80079-36 ⁶⁾	▶ Gas	Ex h IIC T4 Gb X
	▶ Dust	Ex h IIIC T130°C Db X
Maximum surface temperature ⁷⁾	°C 130	
Temperature class	T4	
Type of protection of solenoid	▶ According to EN 60079-7; 60079-18	II 2G Ex eb mb IIC T4 Gb
	▶ According to EN 60079-31	II 2D Ex tb IIIC T130°C Db
Type examination certificate Solenoid	IBExU 16 ATEX 1143 X	
"IECEx Certificate of Conformity" solenoid	IECEx IBE 16.0023X	

**Special application conditions for safe application:**

- ▶ In the event of bank assembly, only one solenoid of all valves may be energized at a time.
- ▶ Maximum admissible dust layer thickness ≤5 mm

Control electronics	
Amplifier in modular design ⁸⁾	VT-MSPA2...1A0... (data sheet 30232-01)
Safety module ⁸⁾	VT-MUXA2-2 (data sheet 30290)

⁶⁾ Ex h: structural safety c according to EN 80079-37.

⁷⁾ Surface temperature > 50 °C, provide contact protection.

⁸⁾ For the electric circuit of valve, amplifier and safety module refer to data sheet 30290 and 30232-01

Characteristic curves

(measured with HLP46, $\vartheta_{oil} = 40 \pm 5 \text{ }^\circ\text{C}$)

Pressure in port P (p_P) dependent on the command value

(measured with a volume flow of 0.8 l/min and the amplifier VT-MSPA2...1A0 with the safety module VT-MUXA2-2)

Pressure rating 50 bar

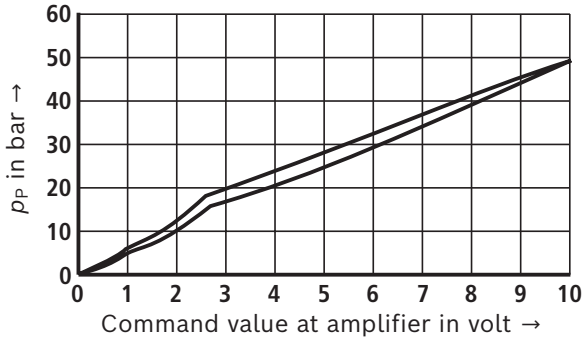

Pressure rating 100 bar

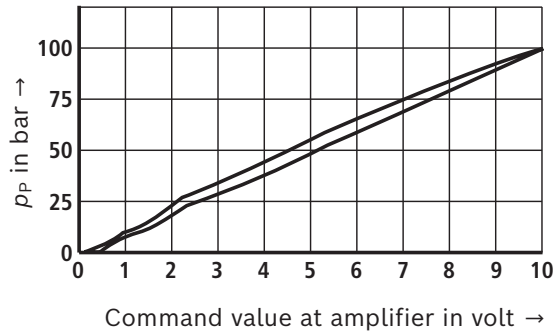

Pressure rating 200 bar

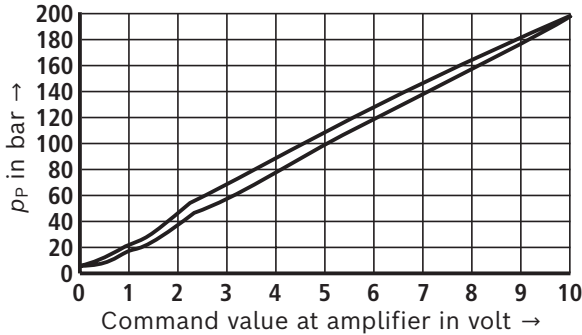

Pressure rating 315 bar

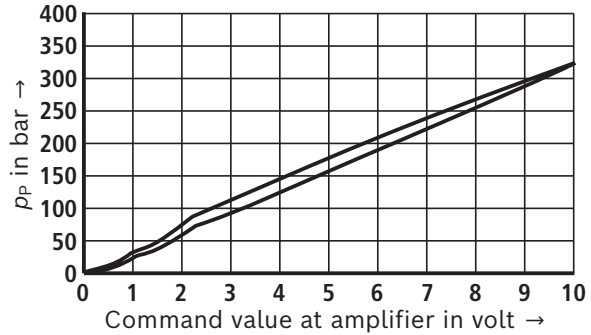

Pressure rating 350 bar

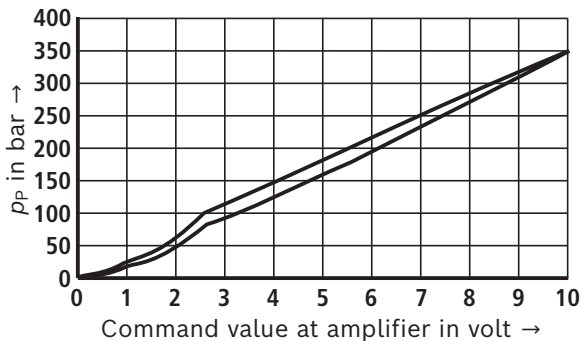

Pressure rating 420 bar

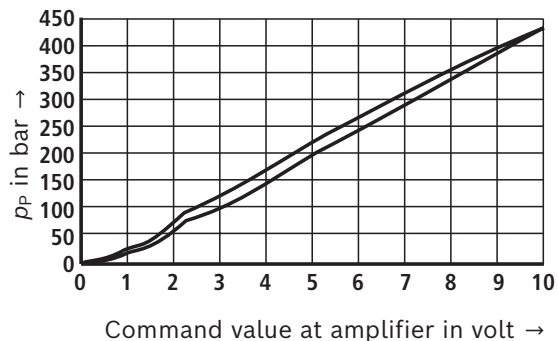

Comparison of the manufacturing tolerance

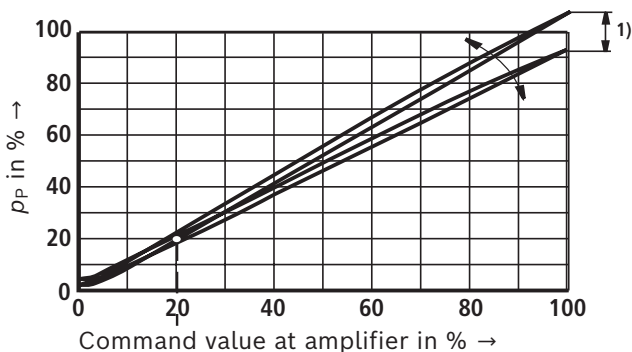

1) The manufacturing tolerance can be compensated at the Gw potentiometer of the upstream VT-MSPA2...1A0 amplifier.



Notice:

Zero point calibration at the factory at 20%

Characteristic curves

(measured with HLP46, $\vartheta_{oil} = 40 \pm 5 \text{ }^\circ\text{C}$)

Pressure in port P (p_P) dependent on the volume flow

(Amplifier VT-MSPA2...1A0... with safety module VT-MUXA2-2)

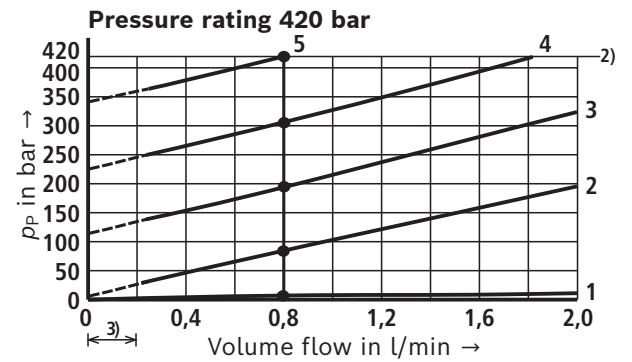
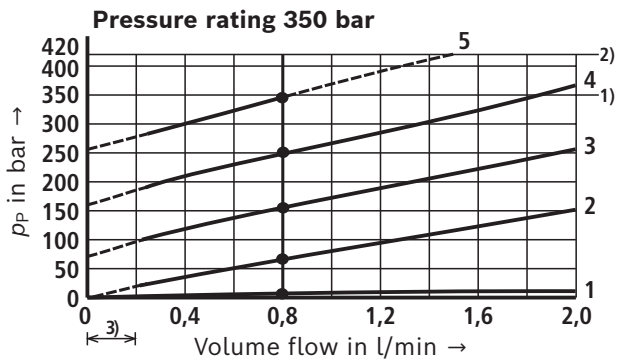
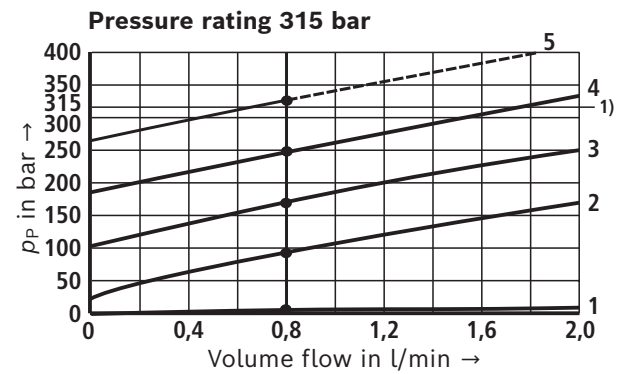
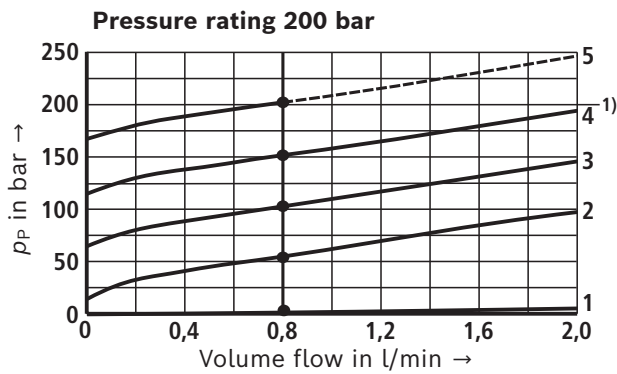
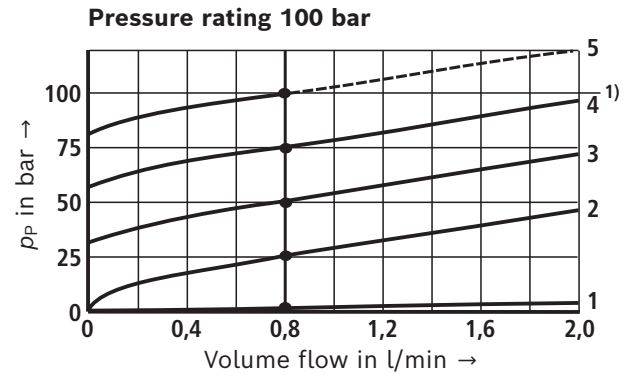
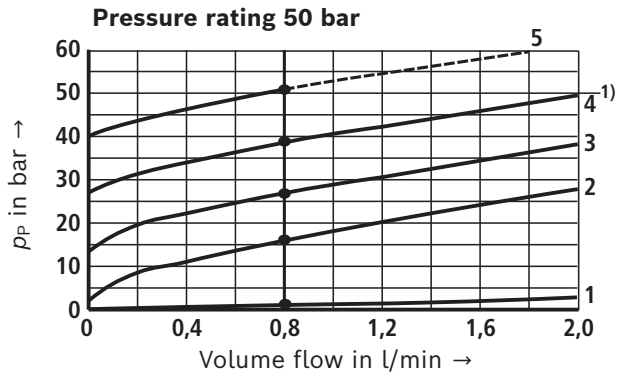

- 1) Flow limit of the pressure rating
- 2) Flow limit and maximum pressure
- 3) Theoretical characteristic curve at a flow $< 0.2 \text{ l/min}$

Applies to all pressure ratings:

- 1 0% command value
- 2 25% command value
- 3 50% command value
- 4 75% command value
- 5 100% command value



Notice:

The characteristic curves were measured without counter pressure in port T ($p_T = 0 \text{ bar}$).

Dimensions
(dimensions in mm)

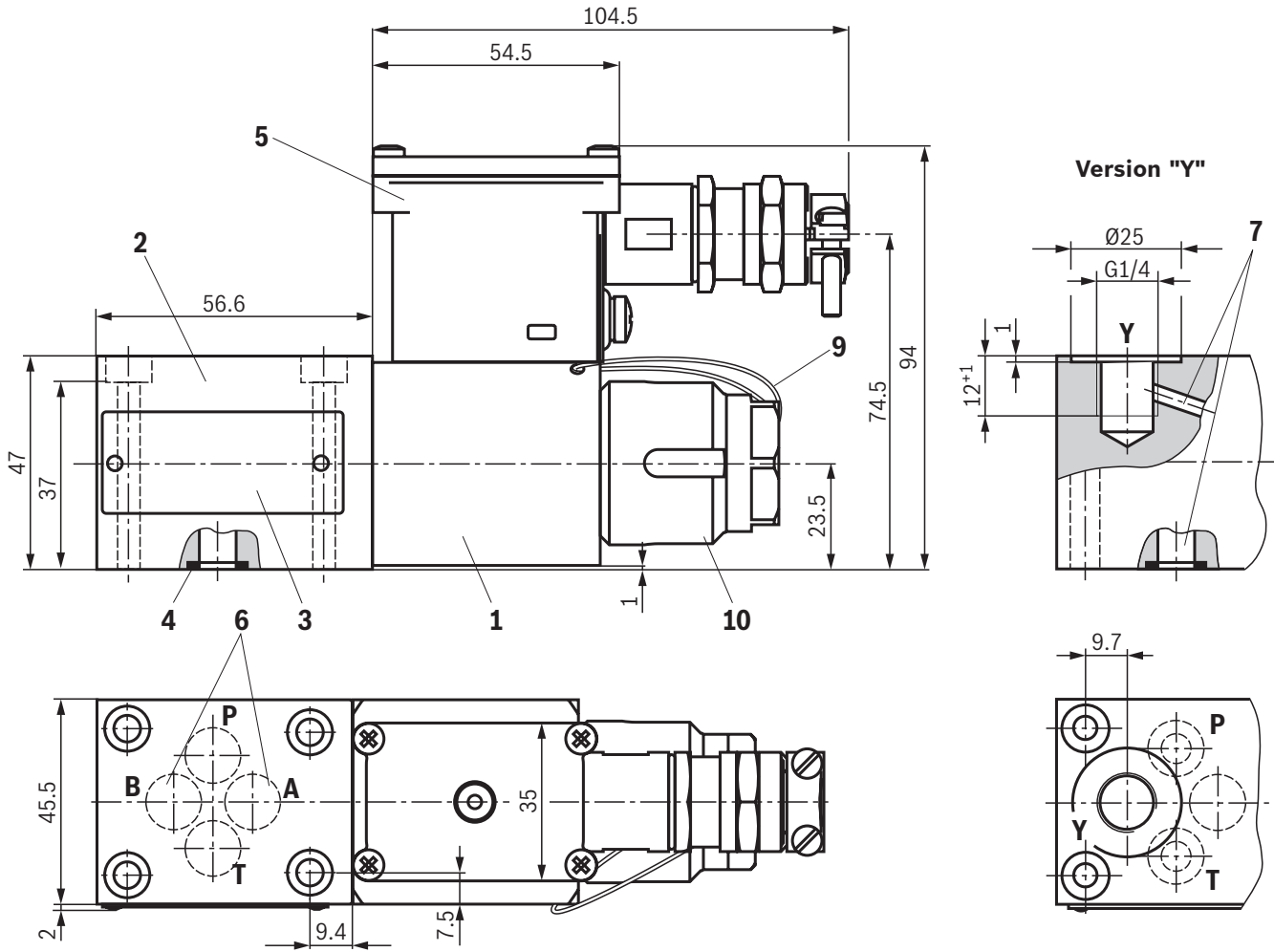

- 1 Proportional solenoid
- 2 Valve housing
- 3 Name plate
- 4 Identical seal rings for ports P, A, B and T
- 5 Terminal box
- 6 Blind counterbores A and B
- 7 With version ..Y.. (external pilot oil return), port Y is internally connected to port T; port T is **not** blocked
- 8 Machined valve contact surface; Porting pattern according to ISO 4401-03-02-0-05
Deviating from the standard:
 - ▶ Locating pin not available
 - ▶ Channel A and B **not** bored
- 9 Securing of the factory setting by locking wire
- 10 Mounting nut for solenoid

Required surface quality of the valve contact surface

Valve mounting screws (separate order)
 Only use valve mounting screws with the subsequently listed thread diameters and strength properties. Observe the screw-in depth.
4 hexagon socket head cap screws ISO 4762 - M5 x 45 - 10.9
 (friction coefficient $\mu_{total} = 0.09 \dots 0.14$);
 Material no. **R913048087**

Installation conditions (dimensions in mm)

	Individual assembly	Bank assembly
Subplate dimensions	Minimum dimensions Length ≥ 69 , width ≥ 57 , height ≥ 25	Minimum cross-section Height ≥ 60 , width ≥ 85
Thermal conductivity of the subplate (referred to 300 °C)	≥ 32.5 W/mK	
Minimum distance between the longitudinal valve axes	≥ 55	

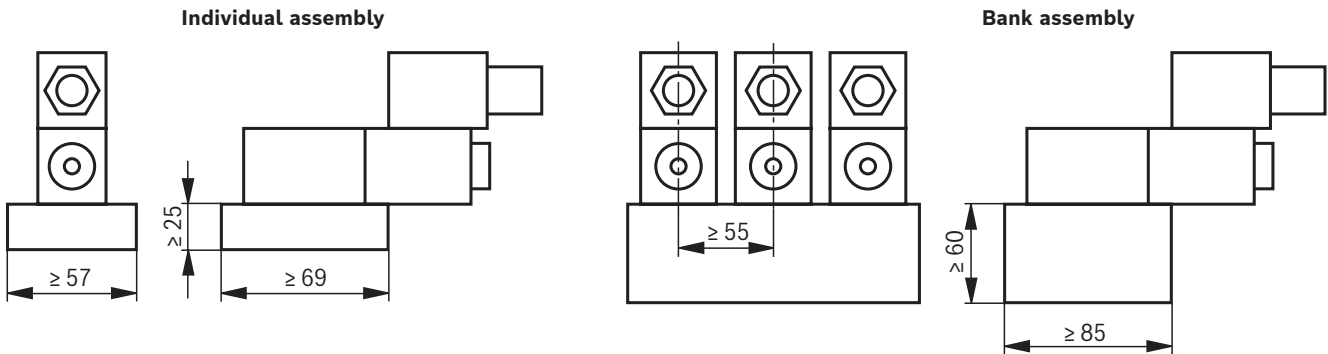

Notice:

Observe the "Special application conditions for safe application" on page 5.

Electrical connection

The type-examination tested actuation solenoid of the valve is equipped with a terminal box and a type-tested cable gland.

The connection is polarity-independent.

 **Notice:**

A fuse which is appropriate for the rated current of the valve solenoid (max. $3 \times I_N$ according to IEC/EN 60127-2) must be installed as short-circuit protection upstream of the valve solenoid. The shut-off threshold of the fuse must match or exceed the short-circuit current of the supply source.

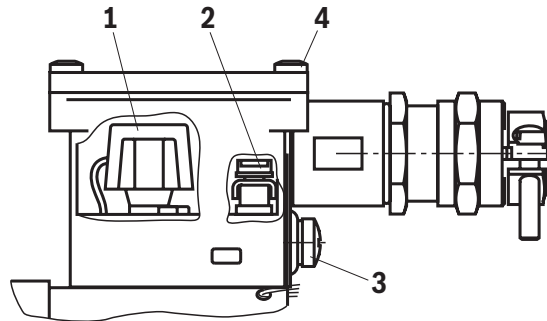

Properties of the connection terminals and mounting elements

Position	Function	Connectable line cross-section
1	Operating voltage connection	single-wire 0.75 ... 2.5 mm ² multi-wire 0.75 ... 1.5 mm ²
2	Connection for protective grounding conductor	single-wire up to 2.5 mm ² multi-wire up to 1.5 mm ²
3	Connection for potential equalization conductor	single-wire up to 4 mm ² multi-wire up to 4 mm ²
4	Screws for cover	-

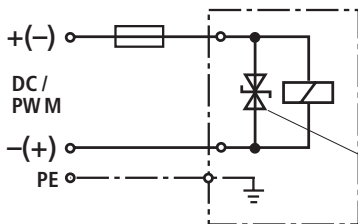

Suppressor diode
internally cast
Type 1,5SMC220CA

 **Notice:**

Only use finely stranded conductors if they have pressed-on wire end ferrules.

Cable gland

Threaded connection	M20 x 1.5
Line diameter	mm 7 ... 12 (three-wire with protective grounding conductor)
Temperature rating	°C -20 ... +130
Protection class according to EN 60529+A1	IP67 in mounted state
Seal material	FKM
Line type	Cable and lines without shielding and reinforcement
Required temperature rating quantities of the connection cable	°C ≥ 115

 **Notice:**

The connection line must be fixed after a minimum of 150 mm to a fixed point.

Over-current fuse and switch-off voltage peaks

Voltage data in the valve type code	Nominal voltage, valve solenoid	Rated current, valve solenoid	Rated current, external miniature fuse: Medium time-lag (M) according to DIN 41571 and EN/IEC 60127	Rated voltage, external miniature fuse: Medium time-lag (M) according to DIN 41571 and EN/IEC 60127	Maximum voltage value when switching off	Interference protection circuit
G24	24 VDC	0.936 ADC	1000 mA	250 V	200 V	Suppressor diode Bi-directional

Notice:

A fuse which corresponds to the rated current according to DIN 41571 and EN / IEC 60127 has to be connected upstream of every valve solenoid (max. $3 \times I_{rated}$).

The shut-off threshold of the fuse has to match the prospective short-circuit current of the supply source.

The prospective short-circuit current of the supply source may amount to a maximum of 1500 A.
This fuse may only be installed outside the potentially explosive atmospheres or must be of an explosion-proof design.
When inductivities are switched off, voltage peaks result which may cause faults in the connected control electronics.

Further information

- ▶ Valve amplifier for proportional valves without electrical position feedback
Maximum current limitation 1 A Data sheet 30232-01
- ▶ Module for monitoring and limiting the solenoid currents with proportional valves Data sheet 30290
- ▶ Subplates Data sheet 45100
- ▶ Hydraulic fluids on mineral oil basis Data sheet 90220
- ▶ Hydraulic valves for industrial applications Operating instructions 07600-B
- ▶ Selection of filters www.boschrexroth.com/filter
- ▶ Information on available spare parts www.boschrexroth.com/spc

Notes

Bosch Rexroth AG
Industrial Hydraulics
Zum Eisengießer 1
97816 Lohr am Main, Germany
Phone +49 (0) 93 52/40 30 20
my.support@boschrexroth.de
www.boschrexroth.de

© All rights reserved to Bosch Rexroth AG, also regarding any disposal, exploitation, reproduction, editing, distribution, as well as in the event of applications for industrial property rights.
The data specified above only serves to describe the product. No statements concerning a certain condition or suitability for a certain application can be derived from our information. The information given does not release the user from the obligation of own judgment and verification.
It must be remembered that our products are subject to a natural process of wear and aging.