

# Proportional directional valves, pilot-operated, without electrical position feedback

## Type 4WRZ ...XE

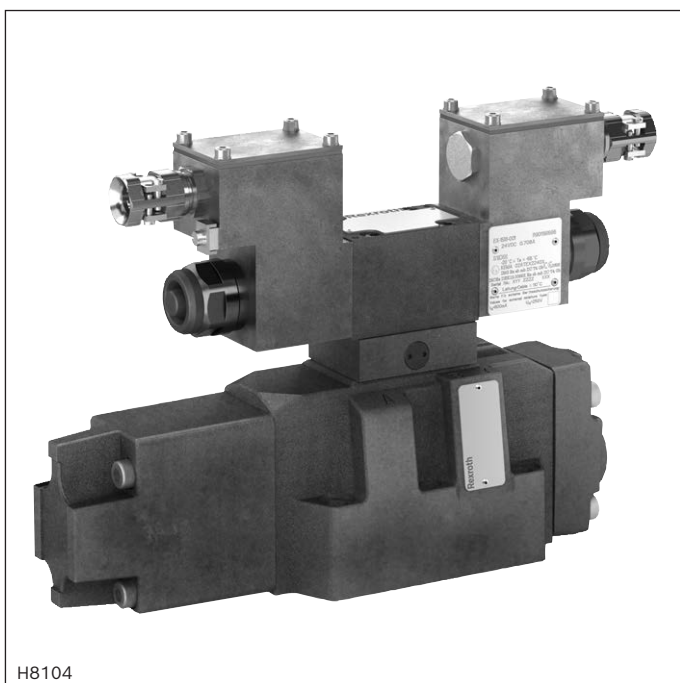

H8104

- ▶ Sizes 10 ... 32
- ▶ Component series 7X
- ▶ Maximum operating pressure 350 bar
- ▶ Maximum flow 1600 l/min



### ATEX units

#### For potentially explosive areas



#### Information on explosion protection:

- ▶ Area of application in accordance with the Explosion Protection Directive 2014/34/EU:  
**II 2G; II 2D**
- ▶ Type of protection valve:
  - Ex h IIC T4 Gb X according to EN 80079-36
  - Ex h IIIC T115°C Db X according to EN 80079-36
- ▶ Type of protection solenoid coil:
  - Ex eb mb IIC T4 Gb according to EN 60079-7 / EN 60079-18
  - Ex tb IIIC T115°C Db according to EN 60079-31
- ▶ Solenoid coil IECEx-certified

### Features

- ▶ 4/2 and 4/3-way version
- ▶ For intended use in a potentially explosive atmosphere
- ▶ For the control of flow direction and size
- ▶ For subplate mounting
- ▶ Porting pattern according to ISO 4401
- ▶ Spring-centered control spool
- ▶ Actuation by means of the pilot control valve (3-way pressure reducing valve)
- ▶ Solenoid coil is rotatable by 90°
- ▶ Electrical connection as individual connection with cable gland

### Contents

Features	1
Ordering code	2
Symbols	3
Function, section	4
Pilot oil supply	5
Technical data	6 ... 8
Characteristic curves	9 ... 12
Dimensions	13 ... 16
Electrical connection	17
Over-current fuse and switch-off voltage peaks	18
Further information	18

 **Notice:** The documentation version with which the product was supplied is valid.

**Ordering code**

01	02	03	04	05	06	07	08	09	10	11	12	13
<b>4WR</b>	<b>Z</b>			<b>-</b>	<b>7X</b>	<b>/</b>	<b>6E</b>	<b>G24</b>	<b>XE</b>	<b>J</b>	<b>/</b>	<b>D3</b>

01	Proportional directional valve	<b>4WR</b>
02	Electro-hydraulic actuation	<b>Z</b>
03	Size 10	<b>10</b>
	Size 16	<b>16</b>
	Size 25	<b>25</b>
	Size 32	<b>32</b>
04	Symbols; possible version see page 3	

**Nominal flow**

05	<b>- Size 10</b>	
	25 l/min	<b>25</b>
	50 l/min	<b>50</b>
	85 l/min	<b>85</b>
	<b>- Size 16</b>	
	125 l/min	<b>125</b>
	180 l/min	<b>180</b>
	<b>- Size 25</b>	
	220 l/min	<b>220</b>
	325 l/min	<b>325</b>
	<b>- Size 32</b>	
	360 l/min	<b>360</b>
	520 l/min	<b>520</b>
06	Component series 70 ... 79 (70 ... 79: unchanged installation and mounting dimensions)	<b>7X</b>
07	Proportional solenoid	<b>6E</b>

**Supply voltage of the control electronics**

08	Direct voltage 24 V	<b>G24</b>
----	---------------------	------------

**Explosion protection**

09	"Increased safety"	<b>XE</b>
	For details, see information on explosion protection, page 8	

**Corrosion resistance (outside)**

10	Increased corrosion protection, galvanized	<b>J</b>
----	--	----------

**Pilot oil supply and pilot oil return (see also page 5)**

11	External pilot oil supply, external pilot oil return	<b>no code</b>
	Internal pilot oil supply, external pilot oil return	<b>E</b>
	Pilot oil supply internal, pilot oil return internal	<b>ET</b>
	Pilot oil supply external, pilot oil return internal	<b>T</b>
12	<b>With</b> pressure reducing valve (preset)	<b>D3</b>

**Seal material (observe compatibility of seals with hydraulic fluid used, see page 7)**

13	NBR seals	<b>M</b>
	FKM seals	<b>V</b>

## Symbols

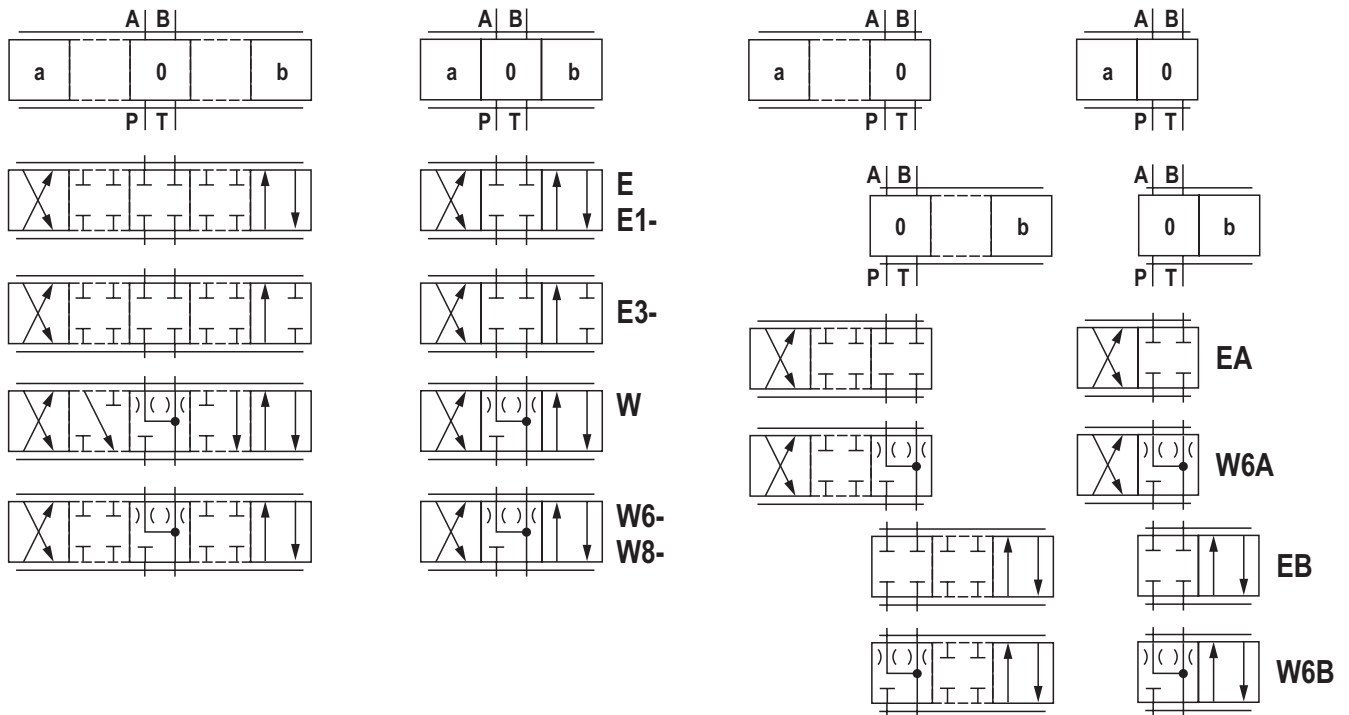

### With symbols E1- and W8-:

$P \rightarrow A: q_{V \max}$      $B \rightarrow T: q_{V/2}$   
 $P \rightarrow B: q_{V/2}$      $A \rightarrow T: q_{V \max}$

### With symbols E3- and W9-:

$P \rightarrow A: q_{V \max}$      $B \rightarrow T: \text{blocked}$   
 $P \rightarrow B: q_{V/2}$      $A \rightarrow T: q_{V \max}$

(Differential circuit, piston top at port A)

### Notice:

- ▶ With symbols W, W6-, W8-, W6A and W6B, in spool position "0", there is a connection from A → T and from B → T with less than 2% of the relevant nominal cross-section.
- ▶ Representation according to DIN ISO 1219-1.
- ▶ Hydraulic interim positions are shown by dashes.

## Function, section

Valves of the type 4WRZ... are pilot-operated proportional directional valves that are actuated by means of proportional solenoids. Their function is to control the flow direction and size.

The proportional solenoids are controlled by external control electronics.

### Set-up

The valve basically consists of:

- ▶ Pilot control valve (4) with proportional solenoids (2 and 3)
- ▶ Pressure reducing valve (9)
- ▶ Main valve (5) with main control spool (6) and centering spring (7)

### Function

- ▶ With de-energized solenoids (2 and 3), the main control spool (6) is held in central position by means of a centering spring (7)
- ▶ The main control spool (6) is controlled by the pilot control valve (4); the main control spool is proportionally moved, e.g. by actuating solenoid "b" (3)

→ The control spool (1) is moved to the right, pilot oil enters the pressure chamber (8) via the pilot control valve (4) and deflects the main control spool (6) proportionally to the electric input signal to the left  
 → Connection from P → A and B → T via orifice-type cross-sections with progressive flow characteristic

- ▶ Pilot oil supply to the pilot control valve internally via port P or externally via port X
- ▶ Switching off the solenoid (3)  
 → The control spool (1) and main control spool (6) are moved back into the central position
- ▶ Flow depending on spool position from P → A and B → T or P → B and A → T.

### Notice:

With pilot control valves of the version "3DREP 6 C", only one solenoid may be actuated at a time.

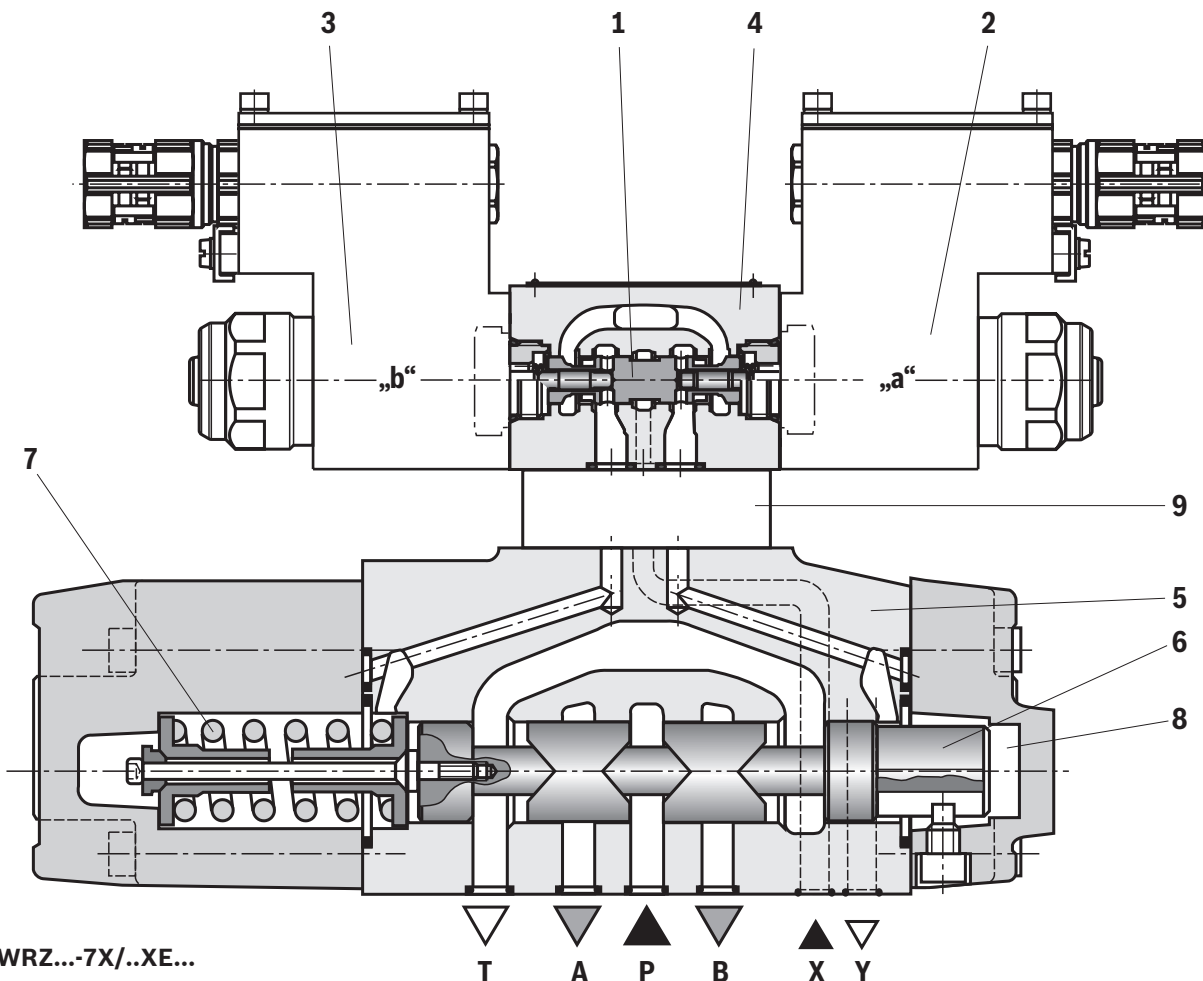

Type 4WRZ...-7X/...XE...

**Pilot oil supply**

3 spool positions	2 spool positions (Version ".A")	
		<p><b>Type 4WRZ ...</b>  <b>External pilot oil supply, external pilot oil return</b>                      The pilot oil is supplied from a separate control circuit (external). The pilot oil return is not directed into channel T of the main valve but is separately directed to the tank via port Y (external).</p>
		<p><b>Type 4WRZ ...E...</b>  <b>Internal pilot oil supply, external pilot oil return</b>                      The pilot oil supply is implemented from channel P of the main valve (internally). The pilot oil return is not directed into channel T of the main valve but is separately directed to the tank via port Y (external).                      In the subplate, port X is to be closed.</p>
		<p><b>Type 4WRZ ...ET...</b>  <b>Pilot oil supply internal, pilot oil return internal</b>                      The pilot oil supply is implemented from channel P of the main valve (internally). The pilot oil is directly returned to channel T of the main valve (internal).                      In the subplate, ports X and Y are to be closed.</p>
		<p><b>Type 4WRZ ...T...</b>  <b>Pilot oil supply external, pilot oil return internal</b>                      The pilot oil is supplied from a separate control circuit (external). The pilot oil is directly returned to channel T of the main valve (internal).                      In the subplate, port Y is to be closed.</p>

**Technical data**

(For applications outside these values, please consult us!)

<b>General</b>						
Size			10	16	25	32
Installation position	Any, preferably horizontal					
Storage temperature range	°C	+5 ... +40				
Maximum storage time	Years	1				
Ambient temperature range	°C	-20 ... +60				
Weight	▶ Valve with one solenoid	kg	8.5	12.5	18.5	44.5
	▶ Valve with two solenoids, spring-centered	kg	10	14	20	46
Surface protection	Galvanized					
Maximum surface temperature	°C	See information on explosion protection, page 8				

<b>Hydraulic</b>						
Maximum operating pressure	▶ Port A, B, P					
	- Internal pilot oil supply	bar	315	315	315	315
	- External pilot oil supply	bar	350	350	350	350
	▶ Port T					
	- Internal pilot oil return	bar	30	30	30	30
	- External pilot oil return	bar	315	250	250	150
	▶ Port X	bar	315	315	315	315
▶ Port Y	bar	30	30	30	30	
Minimum pilot pressure (pilot control valve)	bar	30	30	30	30	
Pilot volume for switching process 0 → 100%	cm <sup>3</sup>	1.7	4.6	10	26.5	
Pilot flow at port X and Y with stepped input signal 0 → 100%	l/min	3.5	5.5	7	15.9	
Maximum flow of the main valve	l/min	170	460	870	1600	
Hydraulic fluid	see table page 7					
Hydraulic fluid temperature range	°C	-20 ... +80 (NBR seals) -15 ... +80 (FKM seals)				
Viscosity range	mm <sup>2</sup> /s	20 ... 380 (preferably 30 ... 46)				
Maximum admissible degree of contamination of the hydraulic fluid Cleanliness class according to ISO 4406 (c)	▶ Pilot control valve	Class 17/15/12 <sup>1)</sup>				
	▶ Main valve	Class 18/16/13 <sup>1)</sup>				
Hysteresis	%	≤ 6				

<sup>1)</sup> The cleanliness classes specified for the components must be adhered to in hydraulic systems. Effective filtration prevents faults and at the same time increases the life cycle of the components.  
Available filters can be found at [www.boschrexroth.com/filter](http://www.boschrexroth.com/filter).

## Technical data

(For applications outside these values, please consult us!)

Hydraulic fluid		Classification	Suitable sealing materials	Standards	Data sheet
Mineral oils		HL, HLP, HLPD, HVLP, HVLPD	NBR, FKM	DIN 51524	90220
Bio-degradable	▶ Insoluble in water	HETG	FKM	ISO 15380	90221
		HEES	FKM		
	▶ Soluble in water	HEPG	FKM	ISO 15380	
Flame-resistant	▶ Water-free	HFDU (glycol base)	FKM	ISO 12922	90222
		HFDU (ester base)	FKM		
		HFDR	FKM		
	▶ Containing water	HFC (Fuchs: Hydrotherm 46M, Renosafe 500; Petrofer: Ultra Safe 620; Houghton: Safe 620; Union: Carbide HP5046)	NBR	ISO 12922	90223



### Important notices on hydraulic fluids:

- ▶ For further information and data on the use of other hydraulic fluids, please refer to the data sheets above or contact us.
- ▶ There may be limitations regarding the technical valve data (temperature, pressure range, life cycle, maintenance intervals, etc.).
- ▶ The ignition temperature of the hydraulic fluid used must be 50 K higher than the maximum surface temperature.
- ▶ **Bio-degradable and flame-resistant – containing water:** If components with galvanic zinc coating (e.g. version "J3" or "J5") or parts containing zinc are used, small amounts of dissolved zinc may get into the hydraulic system and cause accelerated aging of the hydraulic fluid. Zinc soap may form as a chemical reaction product, which may clog filters, nozzles and solenoid valves – particularly in connection with local heat input.

### ▶ Flame-resistant – containing water:

- Due to the increased cavitation tendency with HFC hydraulic fluids, the life cycle of the component may be reduced by up to 30% as compared to the use with mineral oil HLP. In order to reduce the cavitation effect, it is recommended – if possible specific to the installation – backing up the return flow pressure in ports T to approx. 20% of the pressure differential at the component.
- Dependent on the hydraulic fluid used, the maximum environment and hydraulic fluid temperature must not exceed 50 °C. In order to reduce the heat input into the component, the command value profile is to be adjusted for proportional and high-response valves.

**Technical data**

(For applications outside these values, please consult us!)

<b>Electric</b>	
Voltage type	Direct current or pulse-width modulated signal with a pulse voltage $\leq 28$ V and a frequency $\geq 160$ Hz up to max. 500 Hz
Type of signal	analog
Maximum solenoid current	A 1.03
Duty cycle	% 100

<b>Control electronics <sup>2)</sup></b>	
Valve amplifier for proportional valves without electrical position feedback; maximum current limitation 1 A	VT-MSPA2-2X/A5/1A0/000 according to data sheet 30232-01
Module for monitoring and limiting the solenoid currents with proportional valves	VT-MUXA2-2-1X/V0/1A according to data sheet 30290

<b>Information on explosion protection</b>		
Area of application according to directive 2014/34/EU	II 2G	II 2D
Type of protection valve according to EN 80079-36 <sup>3)</sup>	Ex h IIC T4 Gb X	Ex h IIIC T115°C Db X
Maximum surface temperature <sup>4)</sup>	°C 115	
Temperature class	T4	–
Type of protection solenoid coil according to EN 60079-7 / EN 60079-18 / EN 60079-31	Ex eb mb IIC T4 Gb	Ex tb IIIC T115°C Db
Type examination certificate solenoid coil	BVS 20 ATEX E 009 X	
"IECEx Certificate of Conformity" solenoid coil	IECEx BVS 20.0007X	

<sup>2)</sup> A monitoring circuit is to be provided for the monitoring of the solenoid current. We recommend operating the valves with the assemblies described herein. The valve amplifier and the monitoring module may only be installed outside the potentially explosive atmosphere.

<sup>3)</sup> Ex h: Structural safety c according to EN 80079-37.

<sup>4)</sup> Surface temperature  $> 50$  °C, provide contact protection.

 **Special application conditions for safe application:**

- ▶ Connection lines must be installed in a strain-relieved way. The first mounting point must be within 150 mm of the cable and line entry.
- ▶ In case of valves with two solenoids, maximally one of the solenoids may be energized at a time.
- ▶ Only direct voltage or a pulse-width modulated signal with a pulse voltage  $\leq 28$  V and frequency  $\geq 160$  Hz ... up to max. 500 Hz may be used.
- ▶ The maximum temperature of the surface of the valve jacket is 115 °C. This has to be considered when selecting the connection cable and/or contact of the connection cable with the surface of the jacket is to be prevented.



**Characteristic curves:** Size 10  
(measured with symbol E, W6-, EA, W6A, HLP46,  $\vartheta_{oil} = 40 \pm 5 \text{ }^\circ\text{C}$ )

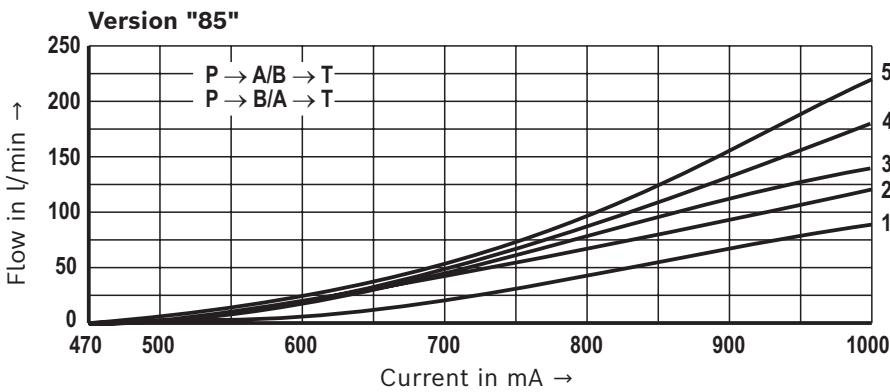
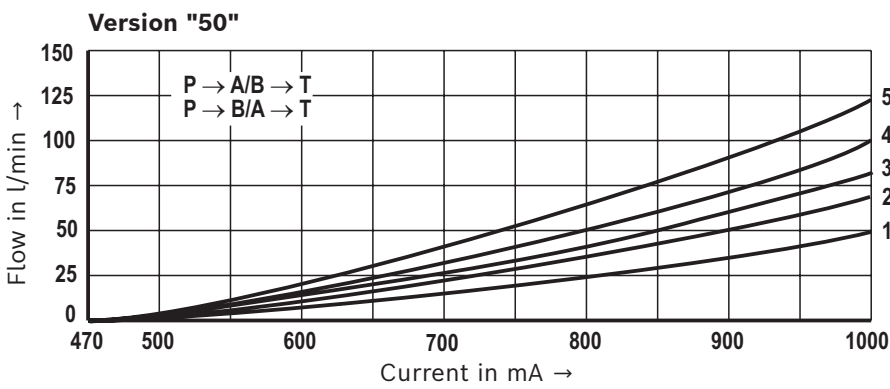
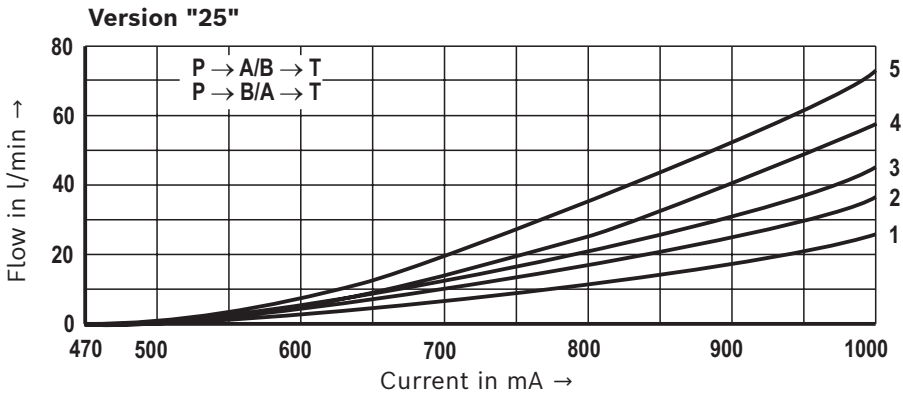

- 1  $\Delta p = 10 \text{ bar constant}$
- 2  $\Delta p = 20 \text{ bar constant}$
- 3  $\Delta p = 30 \text{ bar constant}$
- 4  $\Delta p = 50 \text{ bar constant}$
- 5  $\Delta p = 100 \text{ bar constant}$

$\Delta p = p_P - p_L - p_T$  (according to DIN 24311)

- $\Delta p$  Valve pressure differential
- $p_P$  Inlet pressure
- $p_L$  Load pressure
- $p_T$  Return flow pressure

**Transition function with stepped electric input signals**

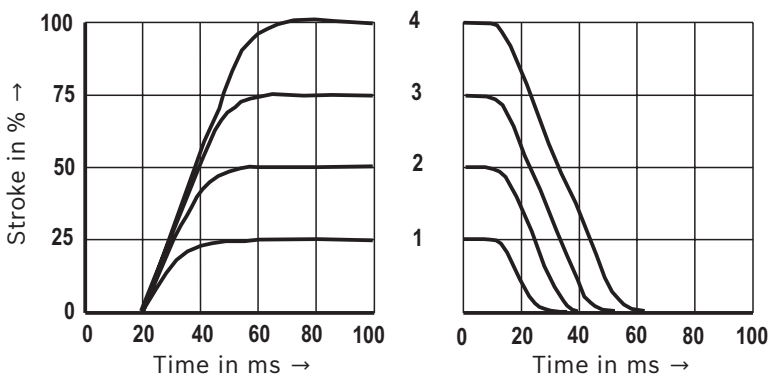

	Change of input signal in %
1	0 → 25 → 0
2	0 → 50 → 0
3	0 → 75 → 0
4	0 → 100 → 0

Measured at pilot pressure  $p_{ST} = 50 \text{ bar}$

**Characteristic curves:** Size 16

(measured with symbol E, W6-, EA, W6A, HLP46,  $\vartheta_{oil} = 40 \pm 5 \text{ }^\circ\text{C}$ )

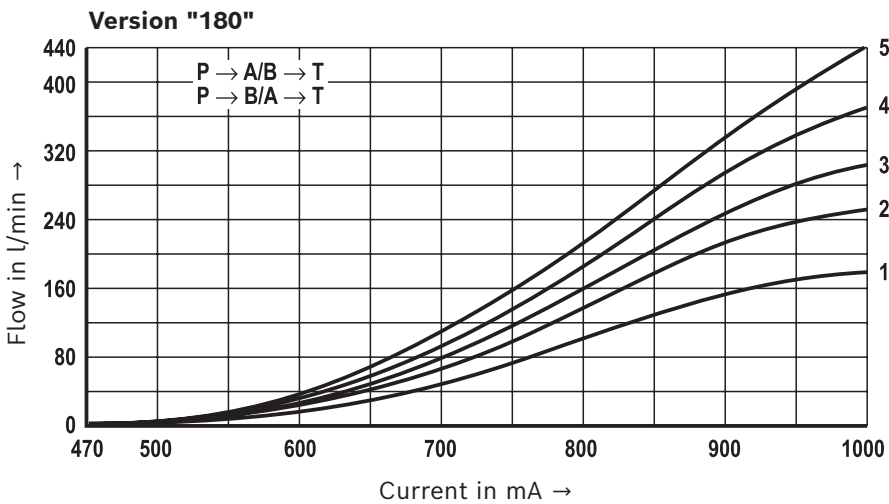
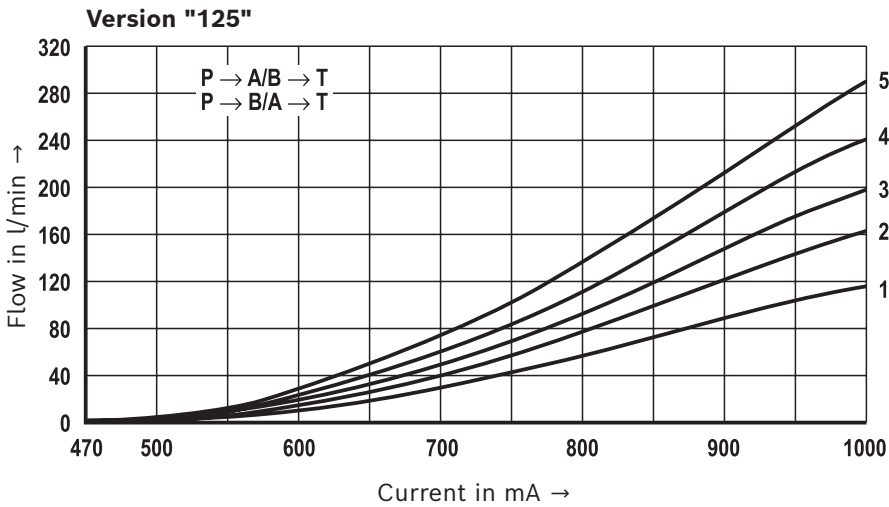

- 1  $\Delta p = 10$  bar constant
- 2  $\Delta p = 20$  bar constant
- 3  $\Delta p = 30$  bar constant
- 4  $\Delta p = 50$  bar constant
- 5  $\Delta p = 100$  bar constant

$\Delta p = p_P - p_L - p_T$  (according to DIN 24311)

- $\Delta p$  Valve pressure differential
- $p_P$  Inlet pressure
- $p_L$  Load pressure
- $p_T$  Return flow pressure

**Transition function with stepped electric input signals**

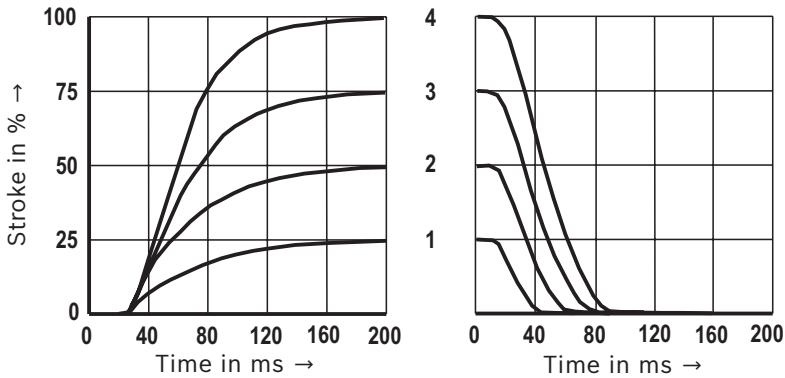

	Change of input signal in %
1	0 → 25 → 0
2	0 → 50 → 0
3	0 → 75 → 0
4	0 → 100 → 0

Measured at pilot pressure  $p_{ST} = 50$  bar

**Characteristic curves: Size 25**

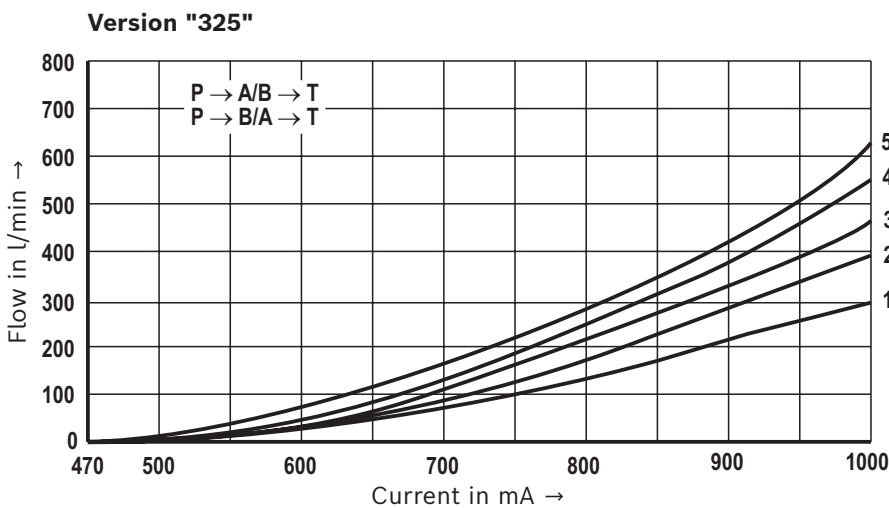
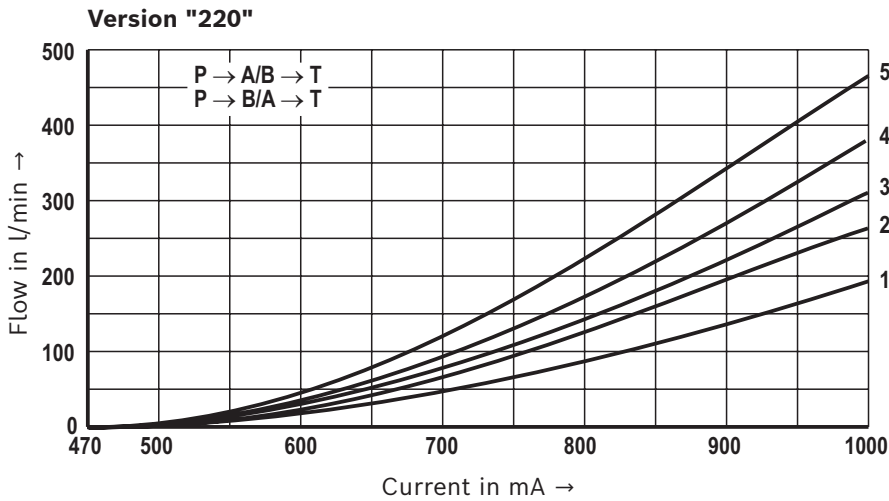
 (measured with symbol E, W6-, EA, W6A, HLP46,  $\vartheta_{oil} = 40 \pm 5 \text{ }^\circ\text{C}$ )

- 1  $\Delta p = 10 \text{ bar constant}$
- 2  $\Delta p = 20 \text{ bar constant}$
- 3  $\Delta p = 30 \text{ bar constant}$
- 4  $\Delta p = 50 \text{ bar constant}$
- 5  $\Delta p = 100 \text{ bar constant}$

$$\Delta p = p_P - p_L - p_T \text{ (according to DIN 24311)}$$

- $\Delta p$  Valve pressure differential
- $p_P$  Inlet pressure
- $p_L$  Load pressure
- $p_T$  Return flow pressure

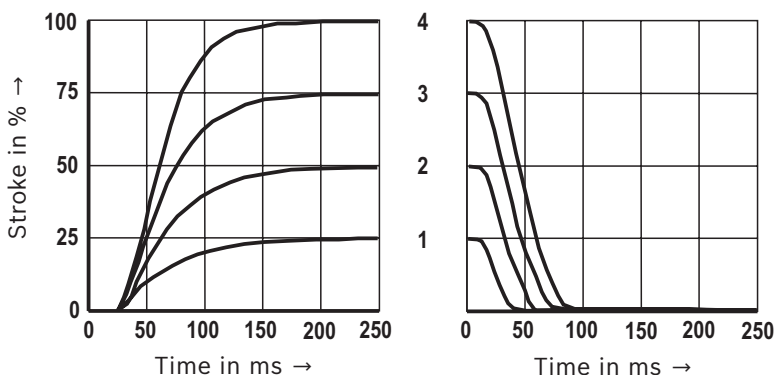
**Transition function with stepped electric input signals**

	Change of input signal in %
1	0 $\rightarrow$ 25 $\rightarrow$ 0
2	0 $\rightarrow$ 50 $\rightarrow$ 0
3	0 $\rightarrow$ 75 $\rightarrow$ 0
4	0 $\rightarrow$ 100 $\rightarrow$ 0

 Measured at pilot pressure  $p_{ST} = 50 \text{ bar}$

**Characteristic curves:** Size 32

(measured with symbol E, W6-, EA, W6A, HLP46,  $\vartheta_{oil} = 40 \pm 5 \text{ }^\circ\text{C}$ )

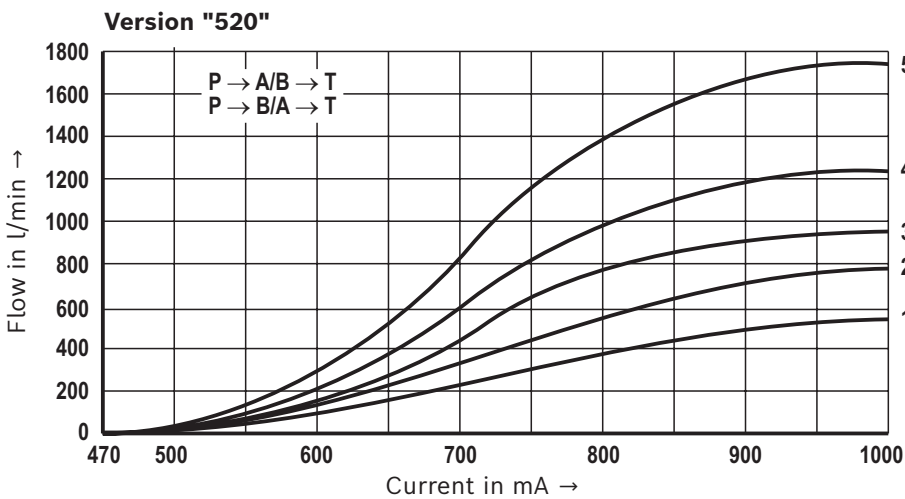
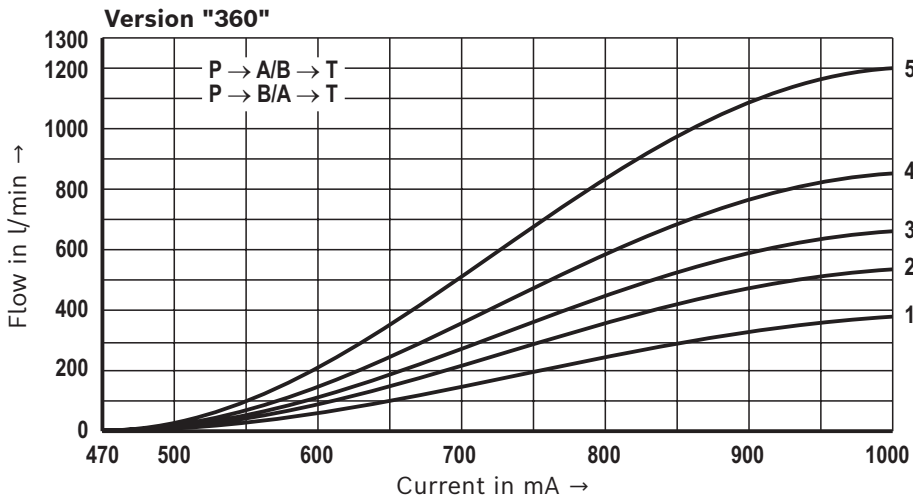

- 1  $\Delta p = 10 \text{ bar constant}$
- 2  $\Delta p = 20 \text{ bar constant}$
- 3  $\Delta p = 30 \text{ bar constant}$
- 4  $\Delta p = 50 \text{ bar constant}$
- 5  $\Delta p = 100 \text{ bar constant}$

$\Delta p = p_P - p_L - p_T$  (according to DIN 24311)

- $\Delta p$  Valve pressure differential
- $p_P$  Inlet pressure
- $p_L$  Load pressure
- $p_T$  Return flow pressure

**Transition function with stepped electric input signals**

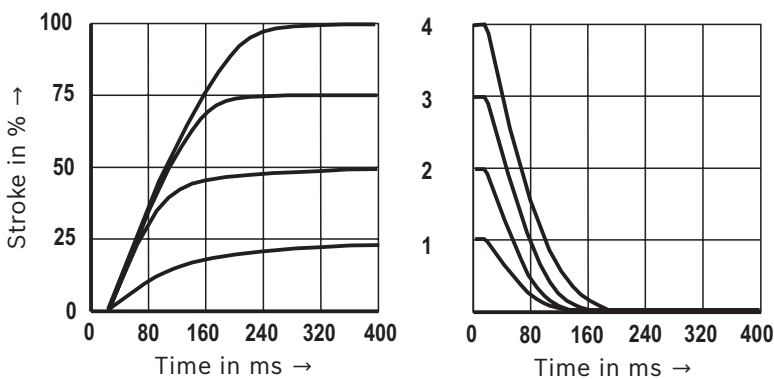

	Change of input signal in %
1	0 → 25 → 0
2	0 → 50 → 0
3	0 → 75 → 0
4	0 → 100 → 0

Measured at pilot pressure  $p_{ST} = 50 \text{ bar}$

**Dimensions:** Size 10  
(dimensions in mm)

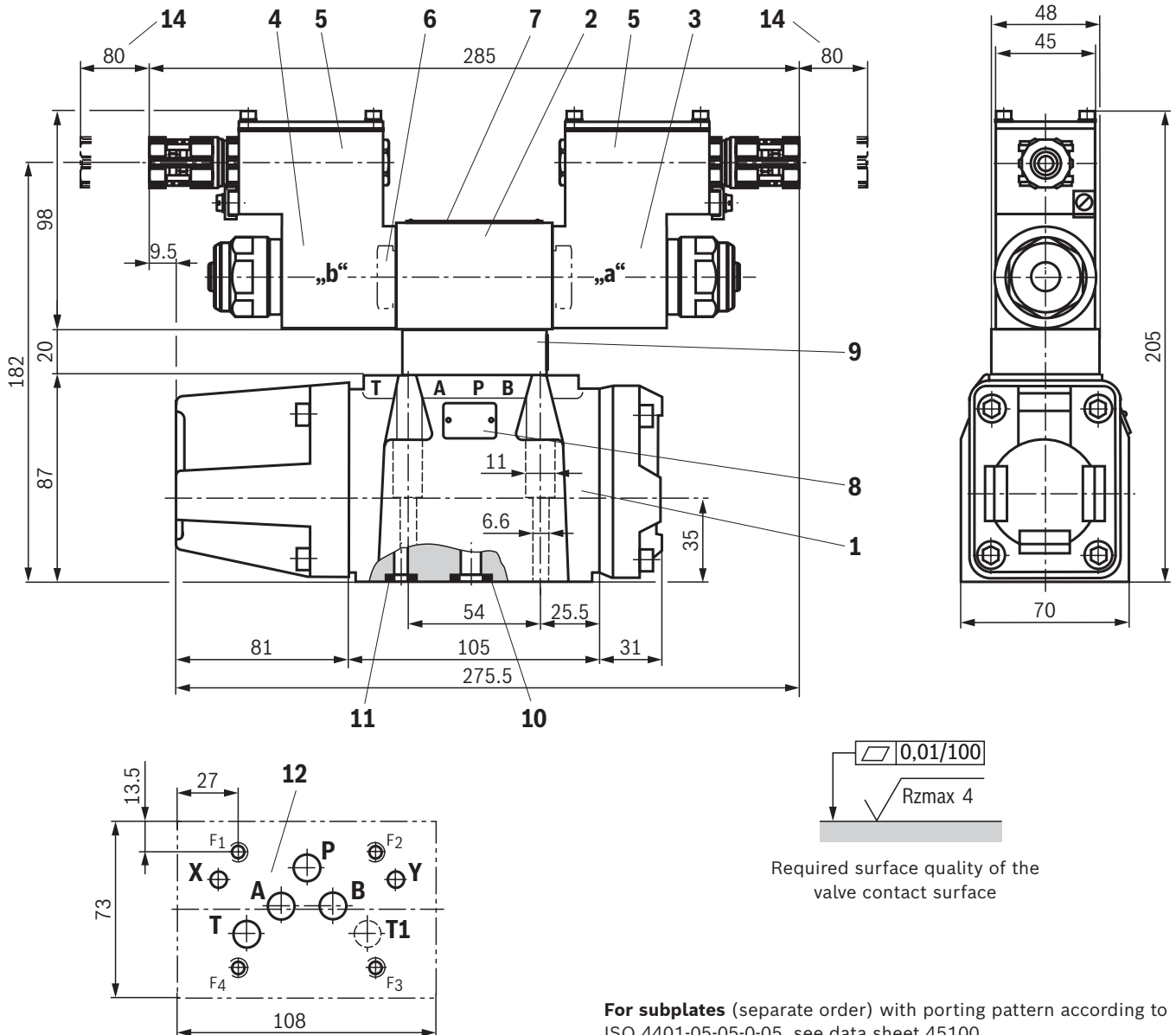

- 1 Main valve
- 2 Pilot control valve
- 3 Proportional solenoid "a"
- 4 Proportional solenoid "b"
- 5 Terminal box
- 6 Plug screw for valves with one solenoid
- 7 Name plate pilot control valve
- 8 Name plate main valve
- 9 Pressure reducing valve (always available)
- 10 Identical seal rings for ports P, A, B, T and T1
- 11 Identical seal rings for X and Y
- 12 Machined valve contact surface, porting pattern according to ISO 4401-05-05-0-05 (X, Y as required, T1 is available at the valve and can optionally be provided)
- 14 Space required to remove the solenoid coil

**For subplates** (separate order) with porting pattern according to ISO 4401-05-05-0-05, see data sheet 45100.

**Valve mounting screws** (separate order)

Only use valve mounting screws with the thread diameters and strength properties listed below. The screw-in depth must be complied with.

**4 hexagon socket head cap screws ISO 4762 - M6 x 45 - 10.9**

(Friction coefficient  $\mu_{\text{total}} = 0.09 \dots 0.14$ )

Tightening torque  $M_A = 13.5 \text{ Nm} \pm 10\%$ ,

Material no. **R913043777**

**Notices:**

- The dimensions are nominal dimensions which are subject to tolerances.
- Subplates are not components in the sense of directive 2014/34/EU and can be used after the manufacturer of the overall system has conducted an assessment of the risk of ignition. The "G...J3" versions are free from aluminum and / or magnesium and galvanized.

**Dimensions:** Size 16  
(dimensions in mm)

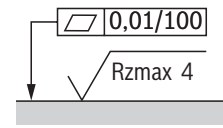
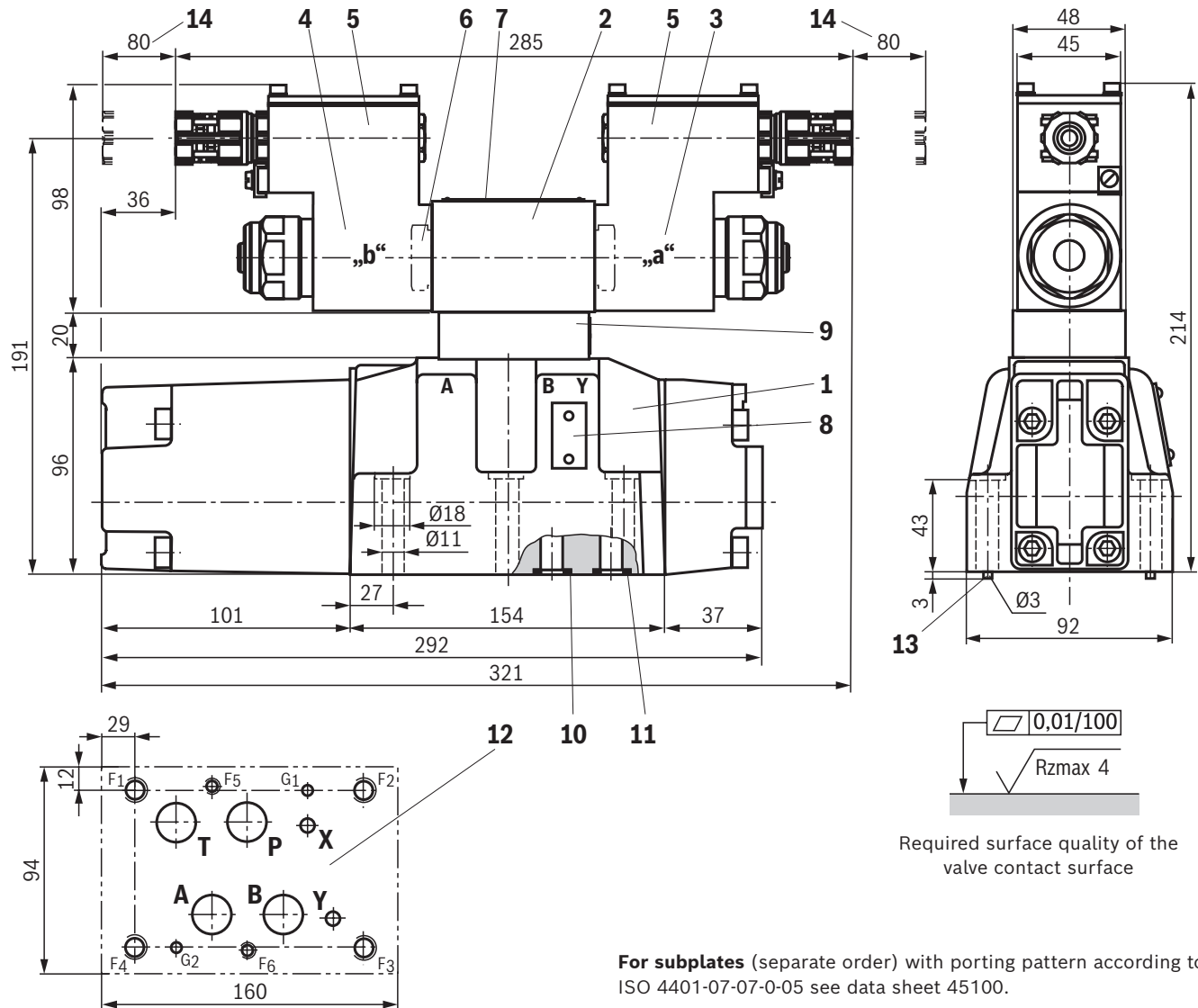

Required surface quality of the valve contact surface

- 1 Main valve
- 2 Pilot control valve
- 3 Proportional solenoid "a"
- 4 Proportional solenoid "b"
- 5 Terminal box
- 6 Plug screw for valves with one solenoid
- 7 Name plate pilot control valve
- 8 Name plate main valve
- 9 Pressure reducing valve (always available)
- 10 Identical seal rings for P, A, B and T (not with version "100" and "150")
- 11 Identical seal rings for X and Y
- 12 Machined valve contact surface; porting pattern according to ISO 4401-07-07-0-05 (X and Y as required)  
Deviating from the standard: Ports P, A, B and T with Ø 20 mm; with version "100" and "150" T with Ø13 mm
- 13 Locating pin
- 14 Space required to remove the solenoid coil

**For subplates** (separate order) with porting pattern according to ISO 4401-07-07-0-05 see data sheet 45100.

**Valve mounting screws** (separate order)

Only use valve mounting screws with the thread diameters and strength properties listed below. The screw-in depth must be complied with.

**2 hexagon socket head cap screws ISO 4762 - M6 x 60 - 10.9**

(Friction coefficient  $\mu_{total} = 0.09 \dots 0.14$ )

Tightening torque  $M_A = 12.2 \text{ Nm} \pm 20\%$ ,

Material no. **R913043410**

**4 hexagon socket head cap screws ISO 4762 - M10 x 60 - 10.9**

(Friction coefficient  $\mu_{total} = 0.09 \dots 0.14$ )

Tightening torque  $M_A = 58 \text{ Nm} \pm 20\%$ ,

Material no. **R913014770**

**Notices:**

- ▶ The dimensions are nominal dimensions which are subject to tolerances.
- ▶ Subplates are not components in the sense of directive 2014/34/EU and can be used after the manufacturer of the overall system has conducted an assessment of the risk of ignition. The "G...J3" versions are free from aluminum and / or magnesium and galvanized.

**Dimensions:** Size 25  
(dimensions in mm)

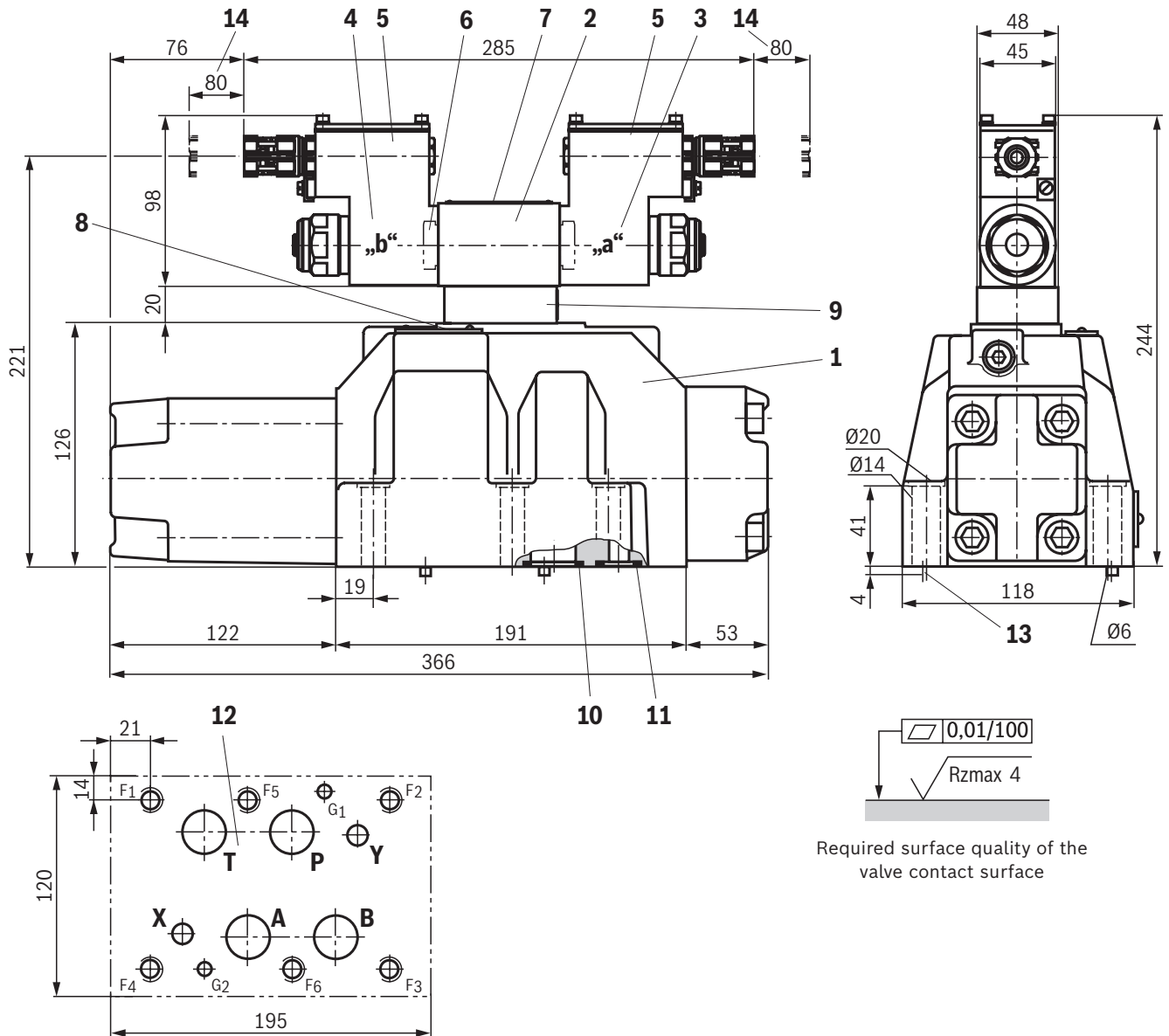

- 1 Main valve
- 2 Pilot control valve
- 3 Proportional solenoid "a"
- 4 Proportional solenoid "b"
- 5 Terminal box
- 6 Plug screw for valves with one solenoid
- 7 Name plate pilot control valve
- 8 Name plate main valve
- 9 Pressure reducing valve (always available)
- 10 Identical seal rings for ports P, A, B and T
- 11 Identical seal rings for X and Y
- 12 Machined valve contact surface; porting pattern according to ISO 4401-08-08-0-05 (ports X and Y as required)
- 13 Locating pin
- 14 Space required to remove the solenoid coil

**For subplates** (separate order) with porting pattern according to ISO 4401-08-08-0-05 see data sheet 45100.

**Valve mounting screws** (separate order)

Only use valve mounting screws with the thread diameters and strength properties listed below. The screw-in depth must be complied with.

**6 hexagon socket head cap screws ISO 4762 - M12 x 60 - 10.9**

(Friction coefficient  $\mu_{total} = 0.09 \dots 0.14$ )

Tightening torque  $M_A = 100 \text{ Nm} \pm 20\%$ ,

Material no. **R913015613**

**Notices:**

- ▶ The dimensions are nominal dimensions which are subject to tolerances.
- ▶ Subplates are not components in the sense of directive 2014/34/EU and can be used after the manufacturer of the overall system has conducted an assessment of the risk of ignition. The "G...J3" versions are free from aluminum and / or magnesium and galvanized.

**Dimensions:** Size 32  
(dimensions in mm)

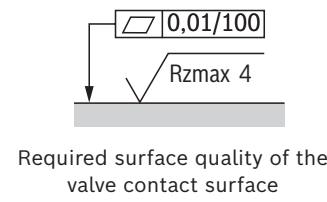
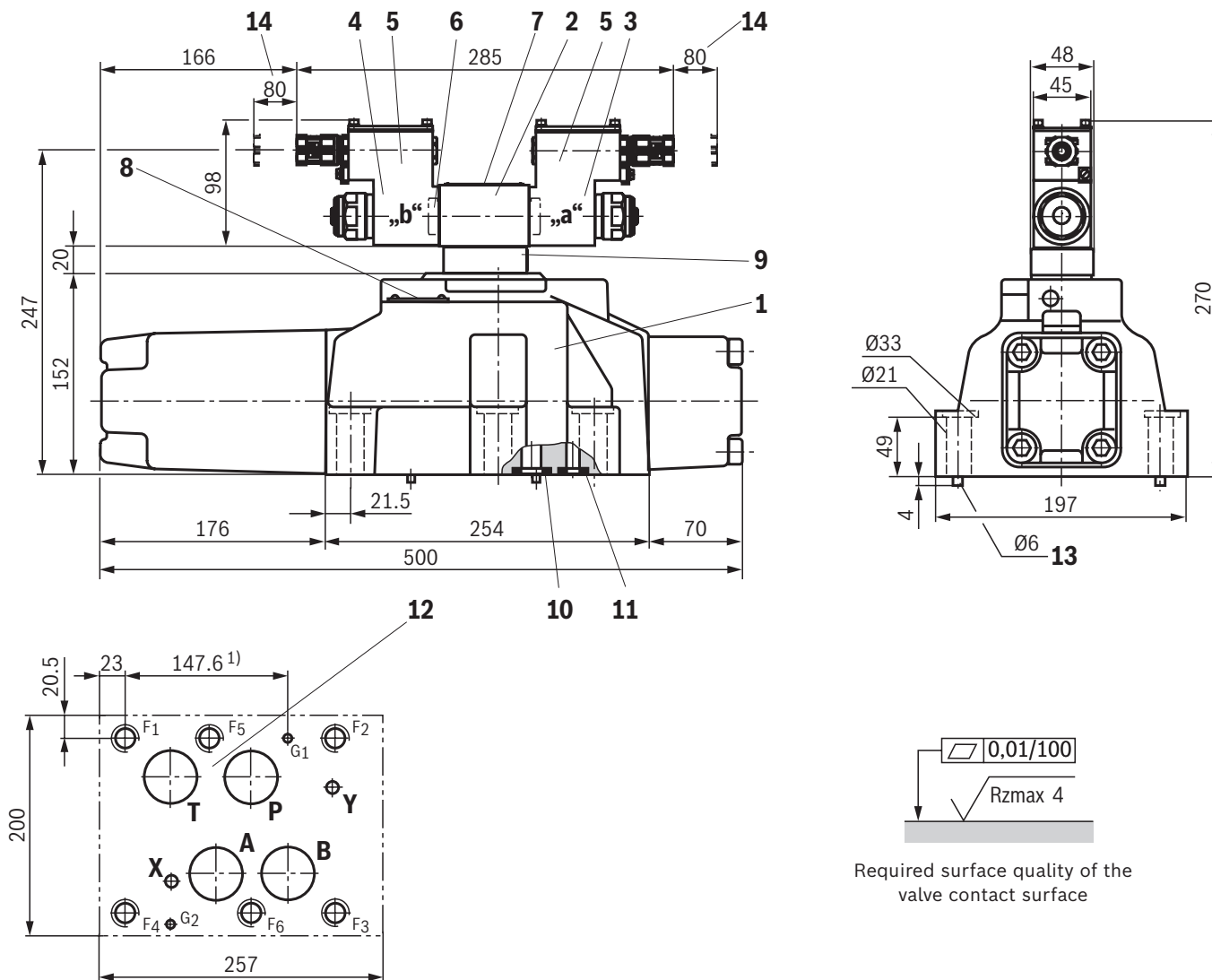

Required surface quality of the valve contact surface

- 1 Main valve
- 2 Pilot control valve
- 3 Proportional solenoid "a"
- 4 Proportional solenoid "b"
- 5 Terminal box
- 6 Plug screw for valves with one solenoid
- 7 Name plate pilot control valve
- 8 Name plate main valve
- 9 Pressure reducing valve (always available)
- 10 Identical seal rings for ports P, A, B and T
- 11 Identical seal rings for X and Y
- 12 Machined valve contact surface; porting pattern according to ISO 4401-10-09-0-05 (ports X and Y as required)  
Deviating from the standard: Ports P, A, B and T with  $\varnothing 38$  mm; position G1 <sup>1)</sup> according to DIN 24340 form A
- 13 Locating pin
- 14 Space required to remove the solenoid coil

**For subplates** (separate order) with porting pattern according to ISO 4401-10-09-0-05 see data sheet 45100.

**Valve mounting screws** (separate order)

Only use valve mounting screws with the thread diameters and strength properties listed below. The screw-in depth must be complied with.

**6 hexagon socket head cap screws ISO 4762 - M20 x 80 - 10.9**

(Friction coefficient  $\mu_{\text{total}} = 0.09 \dots 0.14$ )

Tightening torque  $M_A = 340 \text{ Nm} \pm 20\%$ ,

Material no. **R913008472**

**Notices:**

- ▶ The dimensions are nominal dimensions which are subject to tolerances.
- ▶ Subplates are not components in the sense of directive 2014/34/EU and can be used after the manufacturer of the overall system has conducted an assessment of the risk of ignition. The "G...J3" versions are free from aluminum and / or magnesium and galvanized.



## Electrical connection

The type-examination tested solenoid coil of the valve is equipped with a terminal box, a type-examination tested cable entry and a type-examination tested blind plug. The connection is polarity-independent.

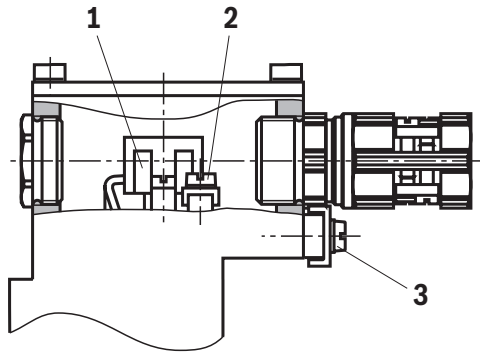

### Notice:

When establishing the electrical connection, the protective grounding conductor (PE  $\perp$ ) has to be connected properly.

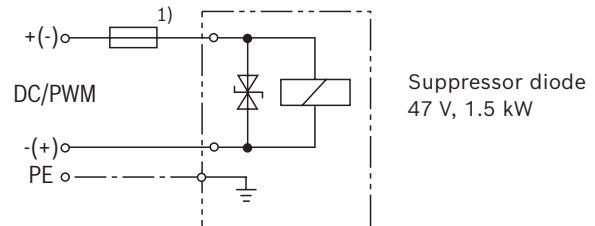

1) Recommended pre-fuse characteristics medium time-lag according to DIN 41571, 1.25 A.

## Properties of the connection terminals and mounting elements

Position	Function	Connectable line cross-section
1	Operating voltage connection	single-wire 0.75 ... 2.5 mm <sup>2</sup> finely stranded 0.75 ... 1.5 mm <sup>2</sup>
2	Connection for protective grounding conductor	single-wire max. 2.5 mm <sup>2</sup> finely stranded max. 1.5 mm <sup>2</sup>
3	Connection for potential equalization conductor	single-wire max. 6 mm <sup>2</sup> finely stranded max. 4 mm <sup>2</sup>

Connection line	
Line type	non-armored and unshielded connection lines
Temperature rating	°C ≤-20 ... ≥+110
Line diameter	mm 7 ... 10.5



### Notice:

Use finely stranded conductors only if they have pressed-on wire end ferrules.

**Over-current fuse and switch-off voltage peaks**

Voltage data in the valve type code	Nominal voltage solenoid coil	Rated current Solenoid coil	Rated current for external miniature fuse: Medium time-lag (M) according to DIN41571 and EN/IEC 60127	Rated voltage of external miniature fuse: Medium time-lag (M) according to DIN41571 and EN/IEC 60127	Maximum voltage value when switching off	Interference protection circuit
G24	24 VDC	1.03 ADC	1.25 A	250 V	-70 V	Suppressor diode bi-directional

 **Notice:**

Corresponding to the rated current, a fuse according to DIN 41571 and EN / IEC 60127 has to be connected upstream of every solenoid coil (max.  $3 \times I_{rated}$ ).

The shut-off threshold of the fuse has to match the prospective short-circuit current of the supply source.

The prospective short-circuit current of the supply source may amount to a maximum of 1500 A.

This fuse may only be installed outside the potentially explosive atmosphere or must be of an explosion-proof design. When inductivities are switched off, voltage peaks occur, which may cause faults in the connected control electronics. For this reason, the solenoid coil comprise an interference protection circuit which dampens this voltage peak to the voltage value shown in the table.

**Further information**

- ▶ Subplates
- ▶ Hydraulic fluids on mineral oil basis
- ▶ Environmentally compatible hydraulic fluids
- ▶ Flame-resistant, water-free hydraulic fluids
- ▶ Flame-resistant hydraulic fluids - containing water (HFAE, HFAS, HFB, HFC)
- ▶ Use of non-electrical hydraulic components in an explosive environment (ATEX)
- ▶ Selection of filters
- ▶ Information on available spare parts

Data sheet 45100

Data sheet 90220

Data sheet 90221

Data sheet 90222

Data sheet 90223

Data sheet 07011

[www.boschrexroth.com/filter](http://www.boschrexroth.com/filter)[www.boschrexroth.com/spc](http://www.boschrexroth.com/spc)

Bosch Rexroth AG  
 Industrial Hydraulics  
 Zum Eisengießer 1  
 97816 Lohr am Main, Germany  
 Phone +49 (0) 93 52/40 30 20  
[my.support@boschrexroth.de](mailto:my.support@boschrexroth.de)  
[www.boschrexroth.de](http://www.boschrexroth.de)

© All rights reserved to Bosch Rexroth AG, also regarding any disposal, exploitation, reproduction, editing, distribution, as well as in the event of applications for industrial property rights.  
 The data specified above only serve to describe the product. No statements concerning a certain condition or suitability for a certain application can be derived from our information. The information given does not release the user from the obligation of own judgment and verification.  
 It must be remembered that our products are subject to a natural process of wear and aging.

## Notes

Bosch Rexroth AG  
Industrial Hydraulics  
Zum Eisengießer 1  
97816 Lohr am Main, Germany  
Phone +49 (0) 93 52/40 30 20  
my.support@boschrexroth.de  
www.boschrexroth.de

© All rights reserved to Bosch Rexroth AG, also regarding any disposal, exploitation, reproduction, editing, distribution, as well as in the event of applications for industrial property rights.  
The data specified above only serve to describe the product. No statements concerning a certain condition or suitability for a certain application can be derived from our information. The information given does not release the user from the obligation of own judgment and verification.  
It must be remembered that our products are subject to a natural process of wear and aging.

## Notes

Bosch Rexroth AG  
Industrial Hydraulics  
Zum Eisengießer 1  
97816 Lohr am Main, Germany  
Phone +49 (0) 93 52/40 30 20  
my.support@boschrexroth.de  
www.boschrexroth.de

© All rights reserved to Bosch Rexroth AG, also regarding any disposal, exploitation, reproduction, editing, distribution, as well as in the event of applications for industrial property rights.  
The data specified above only serve to describe the product. No statements concerning a certain condition or suitability for a certain application can be derived from our information. The information given does not release the user from the obligation of own judgment and verification.  
It must be remembered that our products are subject to a natural process of wear and aging.