

外啮合齿轮泵, U 系列

RC 10 098/02.12

替代对象

RC 10 098/08.07

AZPU-...

定量泵

 $V = 22.5 \dots 63 \text{ cm}^3/\text{rev}$ 

目录

目录	
概述	
产品概况	
订货代码：单级泵	
订货代码：组合泵	
传动轴	
前盖	
管路油口	
齿轮泵，带集成式控制阀	
泵的设计计算	
性能曲线	
噪音曲线	
规格	
传动系的布置	
组合泵的直接传动	
尺寸	
配件	
调试与维护方面的注意事项	
维修零部件	
订货代码	

特点

页号	
2	- 公称压力 280 bar
2	- 采用滑动轴承，适合重负荷应用
3	- 传动轴符合 ISO 或 SAE 要求
4	- 可以实现多台泵的组合
5	- 管路油口：连接法兰
6	- 优化了压力脉动，因而减少了系统的噪音排放和振动输入源
6	- 通过轴的加固型设计和泵盖材料，延长了使用寿命
7	- 通过大规模生产，实现持续的高质量
8	- 可提供多种配置变型
8	
9	
12	
14	
15	
17	
18	
22	
23	
24	
26	

概述

外啮合设备的重要任务，是将机械能（转矩和转速）转变成液压能（流量和压力）；而外啮合齿轮马达则正好相反。这些设备必须具有较高的效率，以避免产生不必要的热量。这种高效率，是通过精密生产工艺和压力敏感型间隙密封而实现的。

而且，在这款低噪音的静音泵之中，这种双齿面原理有助于降低流量脉动，最多可降低75%。

排量方法

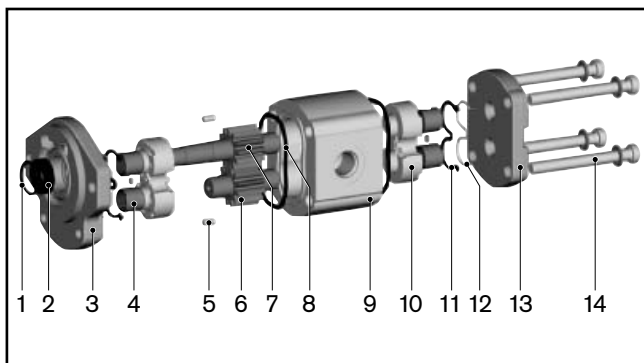
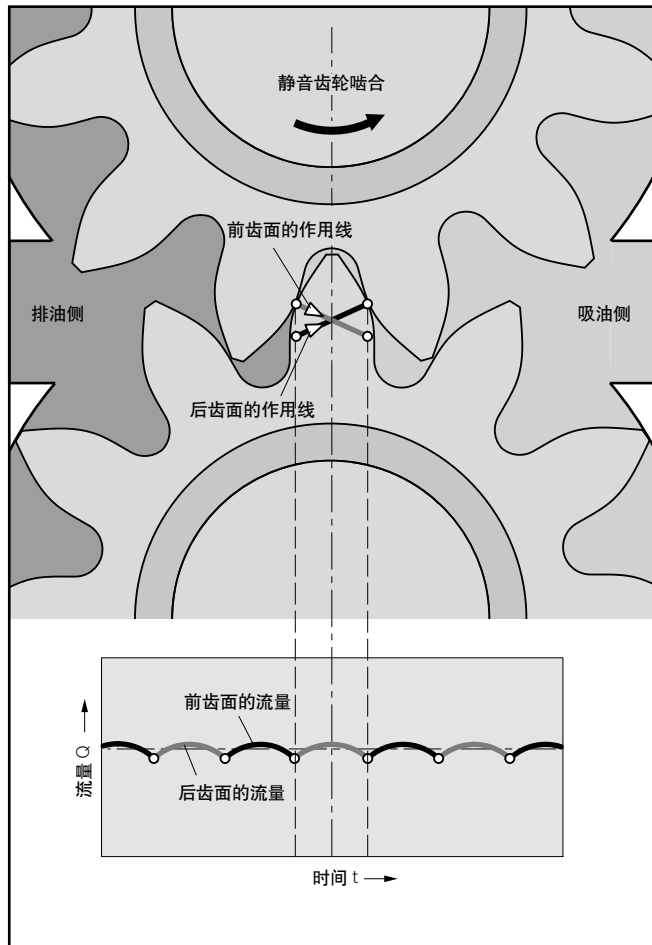
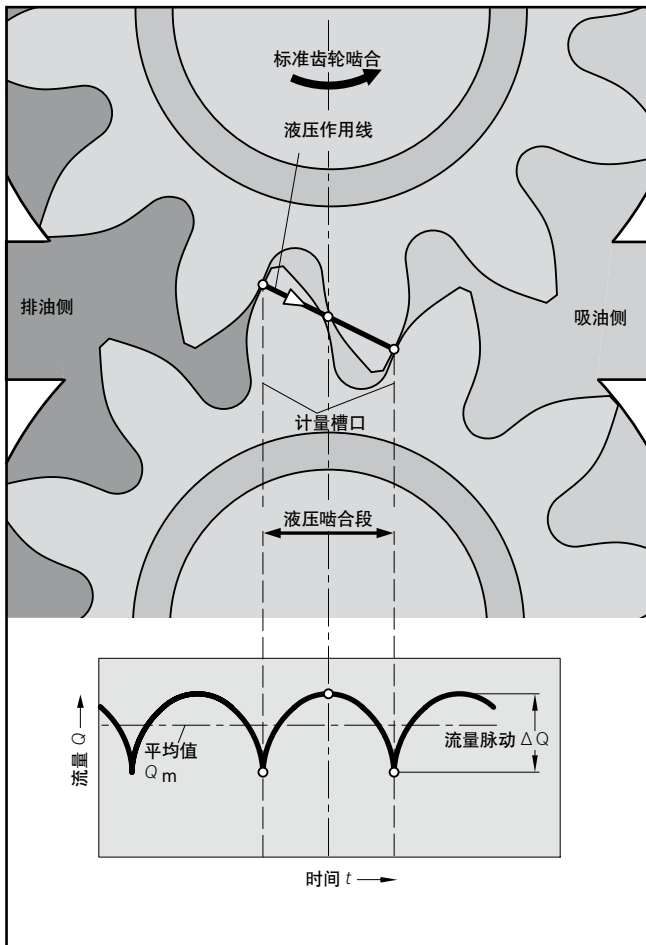

排量齿轮副的密闭区域，与传动轴的旋转方式相配合，从而形成了左图的流量特性曲线（示意性）。在标准型液压泵中，成对的齿轮每啮合一次，在这条特性曲线上就会脉动一次。在采用双齿面结构之后，这种静音泵的流量脉动降低了75%——相应地也降低了下游系统元件上的流量脉动——新的频率等于基础频率的两倍。在这个过程中，齿轮副呈现了一个更小的后齿面齿隙，因而提供液压密封的不仅有被动齿轮的前齿面，而且还包括后齿面。通过这种方式，前、后齿面交替地产生液流排放。而且，通过调节计量槽口的形状，就可以将液压作用线扩展为标准型液压泵的一半。

结构

这款外啮合齿轮泵，主要由支撑在轴承衬套或轴承（取决于不同的系列）上的一对齿轮、以及配备前盖和后盖的泵壳组成。传动轴从泵的前盖向外伸出，并通过轴密封圈加以密封。轴承上的这些支撑力，则由专用的滑动轴承所吸收；由于滑动轴承具有足够的弹性力，因而形成了面接触、而不是线接触的方式。由于这样，因而还确保了泵的出色耐磨性——尤其是在低速运行时。这对齿轮分别有12个齿，从而可保持齿轮泵产生最低限度的流量脉动和噪音。

内部密封是通过补偿力实现的，这些力与输出压力成正比。利用这种补偿方式，就能确保实现最优的效率。通过对轴承衬套的后部输入工作压力，就可以控制介于轮齿与轴承之间的密封区域。这些专用密封件，构成了这一区域的边界。对于轮齿顶部的这些径向间隙，则通过将齿轮推向泵壳的内部作用力而实现密封。

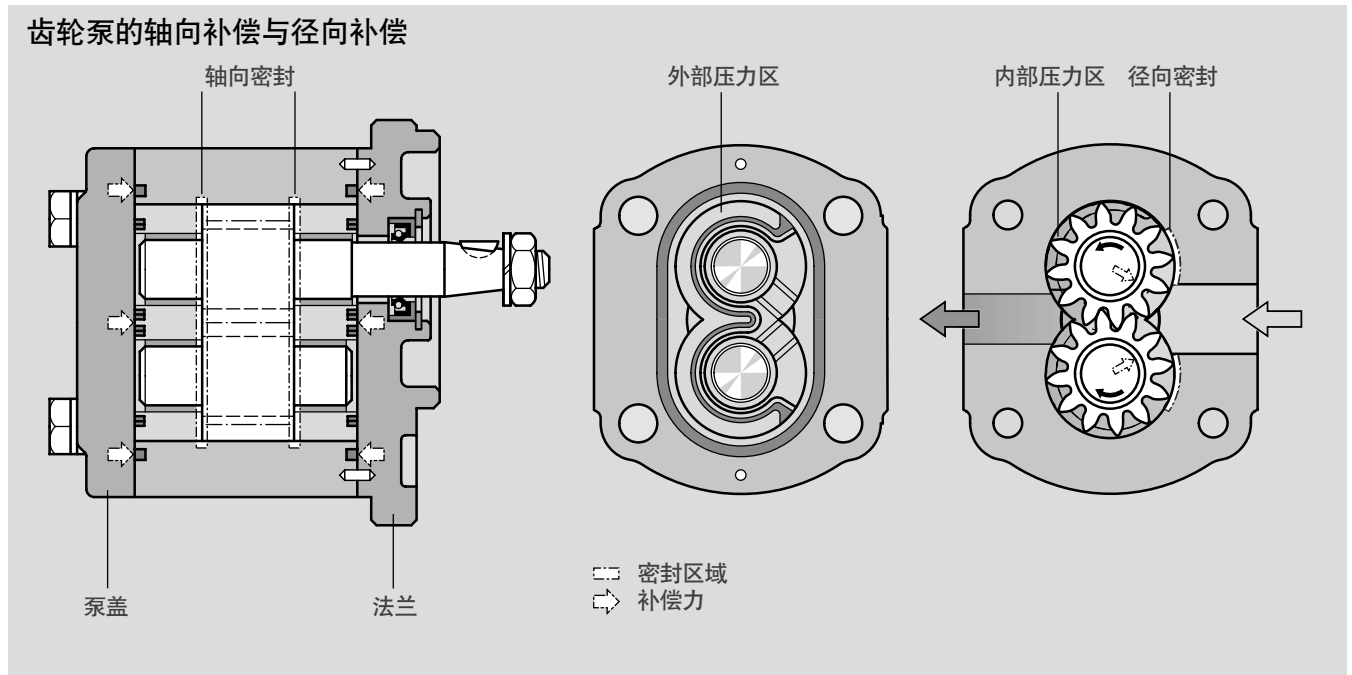

"U 系列" 标准型齿轮泵概览

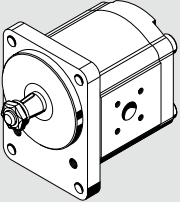
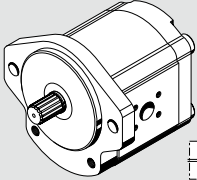
型式	页号	型式	页号
	18		19 20 21

订货代码



























外啮合设备, 单级泵, “静音”型

AZ	P	U	-	2	2	-	063	R	C	B	20	M	D	18009	S xxxx																																																																																																																																																																																																																																																																																																																																																																																										
<table border="1"> <tr> <td>功能</td> <td colspan="14">特殊设计 *)</td> </tr> <tr> <td>P = 泵</td> <td colspan="14"></td> </tr> <tr> <td>系列</td> <td colspan="14"></td> </tr> <tr> <td>2 = 第二代</td> <td colspan="14"></td> </tr> <tr> <td>系列</td> <td colspan="14"></td> </tr> <tr> <td>2 = 耐腐蚀, 销轴连接</td> <td colspan="14"></td> </tr> <tr> <td>系列泵的大小 G</td> <td colspan="14"></td> </tr> <tr> <td>022 = 22.5 cm³/rev</td> <td colspan="14"></td> </tr> <tr> <td>025 = 25.0 cm³/rev</td> <td colspan="14"></td> </tr> <tr> <td>028 = 28.0 cm³/rev</td> <td colspan="14"></td> </tr> <tr> <td>032 = 32.0 cm³/rev</td> <td colspan="14"></td> </tr> <tr> <td>036 = 36.0 cm³/rev</td> <td colspan="14"></td> </tr> <tr> <td>040 = 40.0 cm³/rev</td> <td colspan="14"></td> </tr> <tr> <td>045 = 45.0 cm³/rev</td> <td colspan="14"></td> </tr> <tr> <td>050 = 50.0 cm³/rev</td> <td colspan="14"></td> </tr> <tr> <td>056 = 56.0 cm³/rev</td> <td colspan="14"></td> </tr> <tr> <td>063 = 63.0 cm³/rev</td> <td colspan="14"></td> </tr> <tr> <td>旋转方向</td> <td colspan="14"></td> </tr> <tr> <td>R = 顺时针</td> <td colspan="14"></td> </tr> <tr> <td>L = 逆时针</td> <td colspan="14"></td> </tr> <tr> <td colspan="15">*) 第 18-21 页中所示的一些特殊设计, 并未包含在订货代码的说明示例之中。</td> </tr> <tr> <td colspan="15"> <table border="1"> <tr> <td> 阀的调节 200 xx = PRV 200 bar xxx 11 = FCV 11 l/min 18009 = PRV + FCV 180 bar, 9 l/min </td> </tr> <tr> <td> 后盖 B = 标准 D = PRV 内部残余流量 E = FCV 外部残余流量 S = FCV 内部残余流量 V = PRV + FCV </td> </tr> <tr> <td> 密封件 M = NBR K = NBR, 轴密封圈使用 FKM </td> </tr> </table> </td> </tr> <tr> <td colspan="7"> 传动轴 合适的前盖 <table border="1"> <tr> <td>C</td> <td>锥形键槽轴, 1:5</td> <td></td> <td>B</td> </tr> <tr> <td>D</td> <td>花键轴 SAE J 744 22-4 13T</td> <td></td> <td>C</td> </tr> <tr> <td>H</td> <td>锥形键槽轴, 1:8</td> <td></td> <td>O</td> </tr> </table> </td> <td colspan="5"> 前盖 <table border="1"> <tr> <td>B</td> <td>矩形法兰 定心直径 Ø 105 mm</td> <td></td> </tr> <tr> <td>C</td> <td>SAE J 744 101-2 B 2 孔法兰 Ø 101.6 mm</td> <td></td> </tr> <tr> <td>O</td> <td>矩形法兰 定心直径 Ø 50.78 mm</td> <td></td> </tr> </table> </td> <td colspan="4"> 管路油口 <table border="1"> <tr> <td>20</td> <td>矩形法兰</td> <td></td> </tr> <tr> <td>07</td> <td>方形成法兰 SAE 公制螺纹</td> <td></td> </tr> <tr> <td>30</td> <td>矩形法兰</td> <td></td> </tr> </table> </td> </tr> </table>															功能	特殊设计 *)														P = 泵															系列															2 = 第二代															系列															2 = 耐腐蚀, 销轴连接															系列泵的大小 G															022 = 22.5 cm ³ /rev															025 = 25.0 cm ³ /rev															028 = 28.0 cm ³ /rev															032 = 32.0 cm ³ /rev															036 = 36.0 cm ³ /rev															040 = 40.0 cm ³ /rev															045 = 45.0 cm ³ /rev															050 = 50.0 cm ³ /rev															056 = 56.0 cm ³ /rev															063 = 63.0 cm ³ /rev															旋转方向															R = 顺时针															L = 逆时针															*) 第 18-21 页中所示的一些特殊设计, 并未包含在订货代码的说明示例之中。															<table border="1"> <tr> <td> 阀的调节 200 xx = PRV 200 bar xxx 11 = FCV 11 l/min 18009 = PRV + FCV 180 bar, 9 l/min </td> </tr> <tr> <td> 后盖 B = 标准 D = PRV 内部残余流量 E = FCV 外部残余流量 S = FCV 内部残余流量 V = PRV + FCV </td> </tr> <tr> <td> 密封件 M = NBR K = NBR, 轴密封圈使用 FKM </td> </tr> </table>															阀的调节 200 xx = PRV 200 bar xxx 11 = FCV 11 l/min 18009 = PRV + FCV 180 bar, 9 l/min	后盖 B = 标准 D = PRV 内部残余流量 E = FCV 外部残余流量 S = FCV 内部残余流量 V = PRV + FCV	密封件 M = NBR K = NBR, 轴密封圈使用 FKM	传动轴 合适的前盖 <table border="1"> <tr> <td>C</td> <td>锥形键槽轴, 1:5</td> <td></td> <td>B</td> </tr> <tr> <td>D</td> <td>花键轴 SAE J 744 22-4 13T</td> <td></td> <td>C</td> </tr> <tr> <td>H</td> <td>锥形键槽轴, 1:8</td> <td></td> <td>O</td> </tr> </table>							C	锥形键槽轴, 1:5		B	D	花键轴 SAE J 744 22-4 13T		C	H	锥形键槽轴, 1:8		O	前盖 <table border="1"> <tr> <td>B</td> <td>矩形法兰 定心直径 Ø 105 mm</td> <td></td> </tr> <tr> <td>C</td> <td>SAE J 744 101-2 B 2 孔法兰 Ø 101.6 mm</td> <td></td> </tr> <tr> <td>O</td> <td>矩形法兰 定心直径 Ø 50.78 mm</td> <td></td> </tr> </table>					B	矩形法兰 定心直径 Ø 105 mm		C	SAE J 744 101-2 B 2 孔法兰 Ø 101.6 mm		O	矩形法兰 定心直径 Ø 50.78 mm		管路油口 <table border="1"> <tr> <td>20</td> <td>矩形法兰</td> <td></td> </tr> <tr> <td>07</td> <td>方形成法兰 SAE 公制螺纹</td> <td></td> </tr> <tr> <td>30</td> <td>矩形法兰</td> <td></td> </tr> </table>				20	矩形法兰		07	方形成法兰 SAE 公制螺纹		30	矩形法兰	
功能	特殊设计 *)																																																																																																																																																																																																																																																																																																																																																																																																								
P = 泵																																																																																																																																																																																																																																																																																																																																																																																																									
系列																																																																																																																																																																																																																																																																																																																																																																																																									
2 = 第二代																																																																																																																																																																																																																																																																																																																																																																																																									
系列																																																																																																																																																																																																																																																																																																																																																																																																									
2 = 耐腐蚀, 销轴连接																																																																																																																																																																																																																																																																																																																																																																																																									
系列泵的大小 G																																																																																																																																																																																																																																																																																																																																																																																																									
022 = 22.5 cm ³ /rev																																																																																																																																																																																																																																																																																																																																																																																																									
025 = 25.0 cm ³ /rev																																																																																																																																																																																																																																																																																																																																																																																																									
028 = 28.0 cm ³ /rev																																																																																																																																																																																																																																																																																																																																																																																																									
032 = 32.0 cm ³ /rev																																																																																																																																																																																																																																																																																																																																																																																																									
036 = 36.0 cm ³ /rev																																																																																																																																																																																																																																																																																																																																																																																																									
040 = 40.0 cm ³ /rev																																																																																																																																																																																																																																																																																																																																																																																																									
045 = 45.0 cm ³ /rev																																																																																																																																																																																																																																																																																																																																																																																																									
050 = 50.0 cm ³ /rev																																																																																																																																																																																																																																																																																																																																																																																																									
056 = 56.0 cm ³ /rev																																																																																																																																																																																																																																																																																																																																																																																																									
063 = 63.0 cm ³ /rev																																																																																																																																																																																																																																																																																																																																																																																																									
旋转方向																																																																																																																																																																																																																																																																																																																																																																																																									
R = 顺时针																																																																																																																																																																																																																																																																																																																																																																																																									
L = 逆时针																																																																																																																																																																																																																																																																																																																																																																																																									
*) 第 18-21 页中所示的一些特殊设计, 并未包含在订货代码的说明示例之中。																																																																																																																																																																																																																																																																																																																																																																																																									
<table border="1"> <tr> <td> 阀的调节 200 xx = PRV 200 bar xxx 11 = FCV 11 l/min 18009 = PRV + FCV 180 bar, 9 l/min </td> </tr> <tr> <td> 后盖 B = 标准 D = PRV 内部残余流量 E = FCV 外部残余流量 S = FCV 内部残余流量 V = PRV + FCV </td> </tr> <tr> <td> 密封件 M = NBR K = NBR, 轴密封圈使用 FKM </td> </tr> </table>															阀的调节 200 xx = PRV 200 bar xxx 11 = FCV 11 l/min 18009 = PRV + FCV 180 bar, 9 l/min	后盖 B = 标准 D = PRV 内部残余流量 E = FCV 外部残余流量 S = FCV 内部残余流量 V = PRV + FCV	密封件 M = NBR K = NBR, 轴密封圈使用 FKM																																																																																																																																																																																																																																																																																																																																																																																								
阀的调节 200 xx = PRV 200 bar xxx 11 = FCV 11 l/min 18009 = PRV + FCV 180 bar, 9 l/min																																																																																																																																																																																																																																																																																																																																																																																																									
后盖 B = 标准 D = PRV 内部残余流量 E = FCV 外部残余流量 S = FCV 内部残余流量 V = PRV + FCV																																																																																																																																																																																																																																																																																																																																																																																																									
密封件 M = NBR K = NBR, 轴密封圈使用 FKM																																																																																																																																																																																																																																																																																																																																																																																																									
传动轴 合适的前盖 <table border="1"> <tr> <td>C</td> <td>锥形键槽轴, 1:5</td> <td></td> <td>B</td> </tr> <tr> <td>D</td> <td>花键轴 SAE J 744 22-4 13T</td> <td></td> <td>C</td> </tr> <tr> <td>H</td> <td>锥形键槽轴, 1:8</td> <td></td> <td>O</td> </tr> </table>							C	锥形键槽轴, 1:5		B	D	花键轴 SAE J 744 22-4 13T		C	H	锥形键槽轴, 1:8		O	前盖 <table border="1"> <tr> <td>B</td> <td>矩形法兰 定心直径 Ø 105 mm</td> <td></td> </tr> <tr> <td>C</td> <td>SAE J 744 101-2 B 2 孔法兰 Ø 101.6 mm</td> <td></td> </tr> <tr> <td>O</td> <td>矩形法兰 定心直径 Ø 50.78 mm</td> <td></td> </tr> </table>					B	矩形法兰 定心直径 Ø 105 mm		C	SAE J 744 101-2 B 2 孔法兰 Ø 101.6 mm		O	矩形法兰 定心直径 Ø 50.78 mm		管路油口 <table border="1"> <tr> <td>20</td> <td>矩形法兰</td> <td></td> </tr> <tr> <td>07</td> <td>方形成法兰 SAE 公制螺纹</td> <td></td> </tr> <tr> <td>30</td> <td>矩形法兰</td> <td></td> </tr> </table>				20	矩形法兰		07	方形成法兰 SAE 公制螺纹		30	矩形法兰																																																																																																																																																																																																																																																																																																																																																													
C	锥形键槽轴, 1:5		B																																																																																																																																																																																																																																																																																																																																																																																																						
D	花键轴 SAE J 744 22-4 13T		C																																																																																																																																																																																																																																																																																																																																																																																																						
H	锥形键槽轴, 1:8		O																																																																																																																																																																																																																																																																																																																																																																																																						
B	矩形法兰 定心直径 Ø 105 mm																																																																																																																																																																																																																																																																																																																																																																																																								
C	SAE J 744 101-2 B 2 孔法兰 Ø 101.6 mm																																																																																																																																																																																																																																																																																																																																																																																																								
O	矩形法兰 定心直径 Ø 50.78 mm																																																																																																																																																																																																																																																																																																																																																																																																								
20	矩形法兰																																																																																																																																																																																																																																																																																																																																																																																																								
07	方形成法兰 SAE 公制螺纹																																																																																																																																																																																																																																																																																																																																																																																																								
30	矩形法兰																																																																																																																																																																																																																																																																																																																																																																																																								

注意：并非所有的变型产品, 都可以通过订货代码来加以选择！
 请您用选型表（标准型）选择需要的齿轮泵, 或咨询博世力士乐相关部门的技术人员。
 可按客户要求提供专用选项。

订货代码

外啮合设备, 多级泵, “静音”型

AZ	P	UUSS	-	x	x	-	032/022/016/005	R	C	B	20	20	20	20	K	B				
<p>功能</p> <p>P = 泵</p> <p>系列</p> <p>B = 1.0...7.1 cm³/rev S = 4.0...28 cm³/rev F = 4.0...28 cm³/rev T = 20.0...36 cm³/rev N = 20.0...36 cm³/rev U = 22.5...63 cm³/rev G = 22.5...63 cm³/rev</p> <p>系列, 与泵的截面1有关</p> <p>2 = 第二代</p> <p>型式, 与泵的截面 1 有关</p> <p>2 = 耐腐蚀, 销轴连接</p> <p>泵的大小</p> <p>对应于每一个系列</p> <p>旋转方向</p> <p>R = 顺时针 L = 逆时针</p>							<p>Rear cover relates to last pump part</p> <p>B = Standard</p> <p>Seals</p> <p>M = NBR P = FKM K = NBR, WDR in FKM WDR relates to pump part 1</p>													
<p>传动轴 对应于泵的部件 1</p> <p>B 系列:</p> <p>H 锥形键槽轴, 1:5  O 合适的前盖</p> <p>F 系列, S 系列:</p> <p>C 锥形键槽轴, 1:5  B</p> <p>H 锥形键槽轴, 1:8  O</p> <p>R 花键轴 SAE J 744 16-4 9T  R</p> <p>N 系列, T 系列:</p> <p>C 锥形键槽轴, 1:5  B</p> <p>D 花键轴 SAE J 744 22-4 13T  C</p> <p>G 系列, U 系列:</p> <p>C 锥形键槽轴, 1:5  B</p> <p>D 花键轴 SAE J 744 22-4 13T  C</p> <p>H 锥形键槽轴, 1:8  O</p>							<p>前盖 对应于泵的部件 1</p> <p>O 方形法兰 定心直径 Ø 25.38 mm </p> <p>B 方形法兰 定心直径 Ø 80 mm </p> <p>O 方形法兰 定心直径 Ø 36.47 mm SAE J 744 82-2 A </p> <p>R 2 螺栓法兰 Ø 82.55 mm </p> <p>B 方形法兰 定心直径 Ø 100 mm SAE J 744 101-2 B </p> <p>C 2 螺栓法兰 定心直径 Ø 101.6 mm </p> <p>B 方形法兰 定心直径 Ø 105 mm SAE J 744 101-2 B </p> <p>C B 2 螺栓法兰 定心直径 Ø 101.6 mm </p> <p>O 方形法兰 定心直径 Ø 50.78 mm </p>							<p>管路油口 泵的每一个部件</p> <p>01 管螺纹 ISO 228/1 </p> <p>20 矩形法兰 </p> <p>20 矩形法兰 </p> <p>30 矩形法兰 </p> <p>07 方形法兰 SAE 公制螺纹 </p> <p>20 矩形法兰 </p> <p>07 方形法兰 SAE 公制螺纹 </p> <p>20 矩形法兰 </p> <p>30 矩形法兰 </p>						

注意: 并非所有的变型产品, 都可以通过订货代码来加以选择!
 请您用选型表 (标准型) 选择需要的齿轮泵, 或咨询博世力士乐相关部门的技术人员。
 可按客户要求提供专用选项。

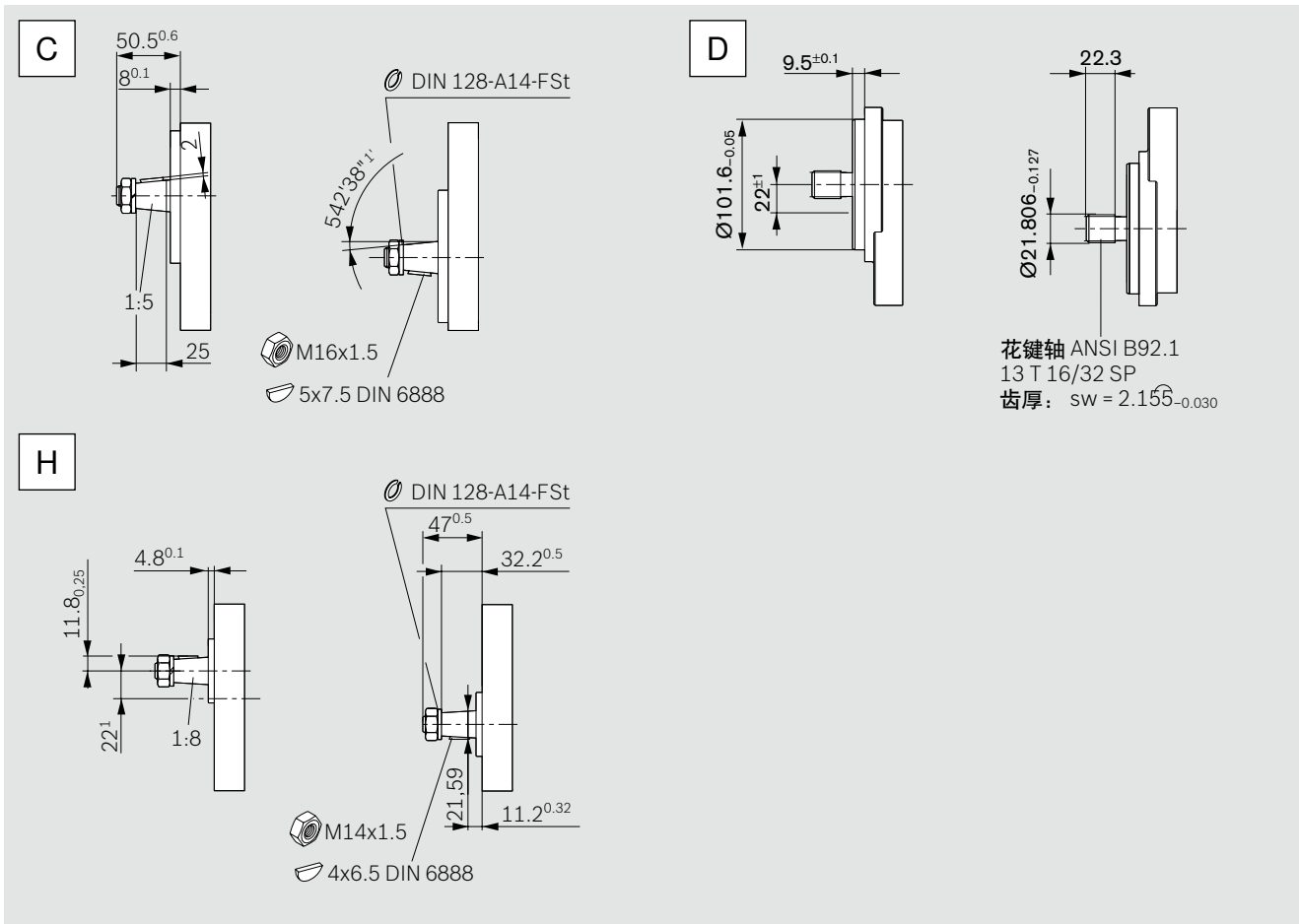

前盖

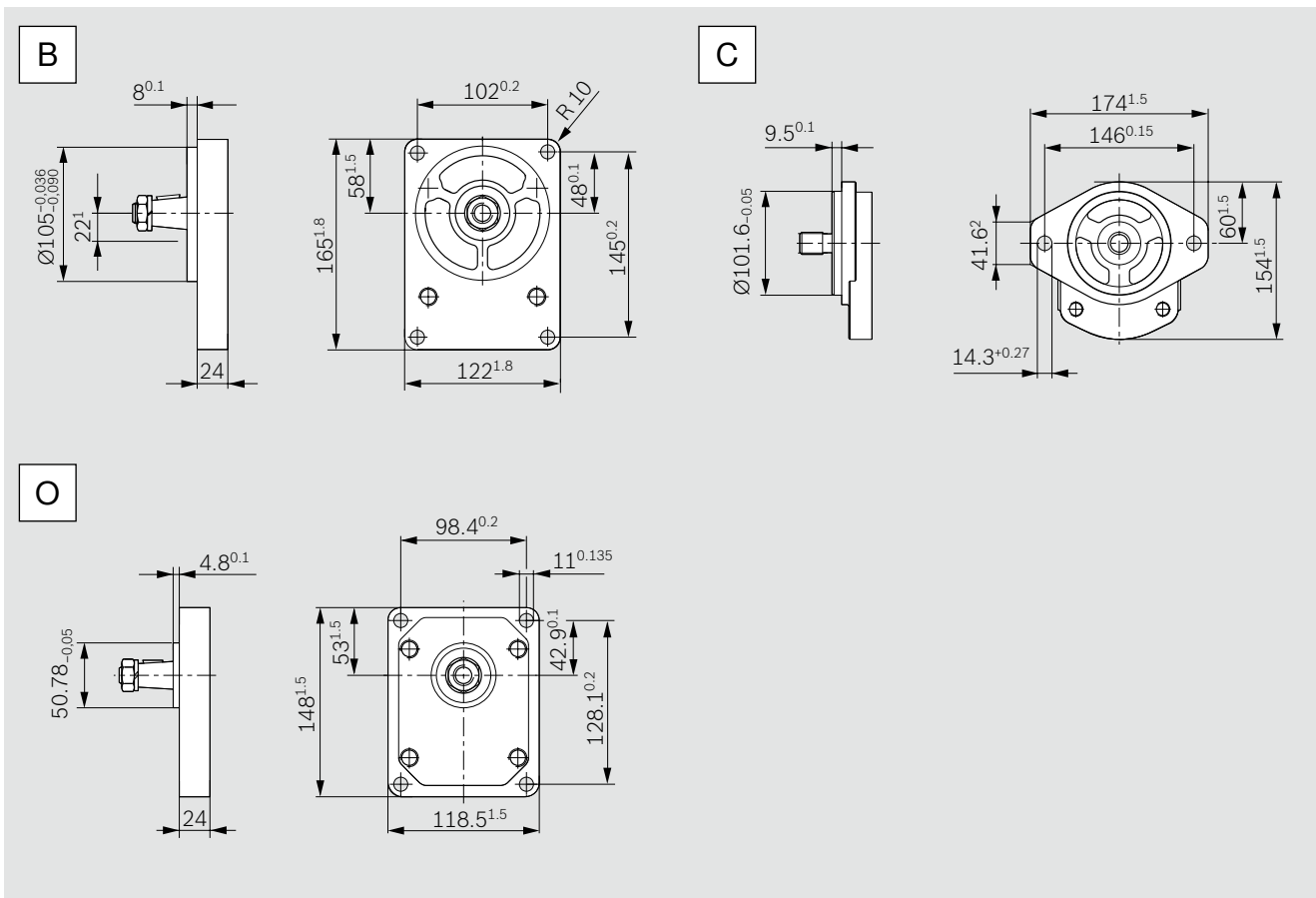

管路油口

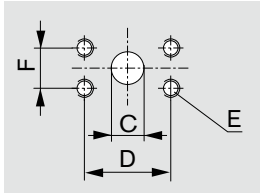

07 方方法兰 SAE, 公制螺纹

订货代码	泵的大小	压力侧				吸油侧			
		C	D	E	F	C	D	E	F
07	22.5...28 cm ³	18	47.6	M10 深度 18	22.2	25	52.4	M10 深度 14	26.2
	32.0...50 cm ³	25	52.4		26.2	32	58.7		30.2
56.0...63 cm ³	32	58.7	30.2		38	69.8	35.8		

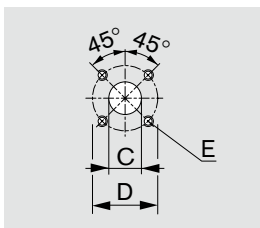

20 矩形法兰

订货代码	泵的大小	压力侧			吸油侧		
		C	D	E	C	D	E
20	22.5...63 cm ³	18	55	M8 深度 13	26	55	M8 深度 13

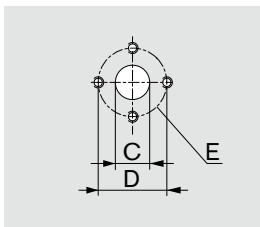

30 矩形法兰

订货代码	泵的大小	压力侧			吸油侧		
		C	D	E	C	D	E
30		18	39.7	M8 深度 13	26	50.8	M10 深度 13

齿轮泵， 带集成式控制阀

为减少外部管路，可以将流量控制阀或溢流阀组合到齿轮泵的泵盖之中。这种结构的典型应用，就是动力转向系统中的液压供油。齿轮泵输出恒定的流量，并与驱动转速无关。多余的流量既可经内部油路回到吸油口，也通过外部管道输送给其它设备。

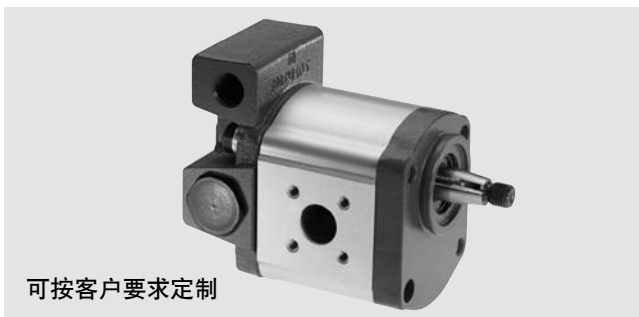

可按客户要求定制

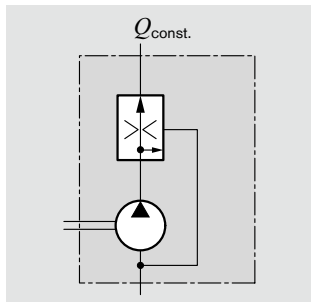

三通流量控制阀
多余的流量回到吸油管路

$Q_{const.} = 2...30 \text{ l/min}$

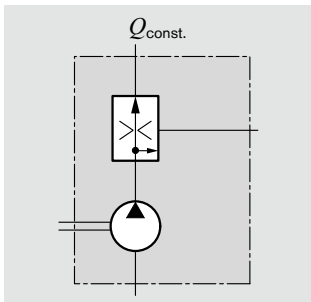

三通流量控制阀
过剩的流量经外部排出；可承载

$Q_{const.} = 2...30 \text{ l/min}$

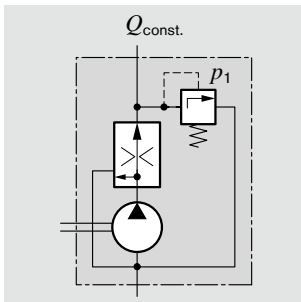

三通流量控制阀，带有溢流阀
多余的流量回到吸油管路

$Q_{const.} = 2...30 \text{ l/min}$
 $p_1 = 100...180 \text{ bar}$

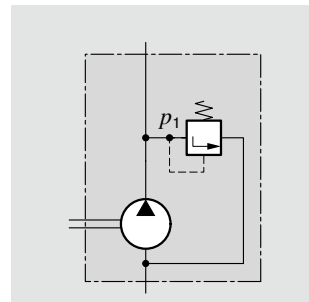

溢流阀
排出的油液回到吸油管路

$p_1 = 5...250 \text{ bar}$

订货代码

S	xxx17
---	-------

E	xxx12
---	-------

V	15011
---	-------

D	180xx
---	-------

泵的设计计算

泵的设计计算依据以下参数：

V [cm ³ /rev]	排量
Q [l/min]	流量
p [bar]	压力
M [Nm]	驱动扭矩
n [rev/min]	驱动转速
P [kW]	驱动功率

此外，还需要计算各种不同的效率值，比如：

η_v	容积效率
η_{hm}	液压-机械效率
η_t	总效率

通过这些公式，描述了各种不同变量之间的关系。

其中还包含一些换算系数，以便将这些参数转变为实际情况中经常遇到的一些数据单位。

提醒：关于选择近似数据时常用的一些曲线，可参见以下各页。

$$Q = V \cdot n \cdot \eta_v \cdot 10^{-5}$$

$$p = \frac{M \cdot \eta_{hm}}{1.59 \cdot V}$$

$$P = \frac{p \cdot Q}{6 \cdot \eta_t}$$

$$V = \frac{Q}{n \cdot \eta_v} \cdot 10^5$$

$$V = \frac{M \cdot \eta_{hm}}{159 \cdot p}$$

$$Q = \frac{6 \cdot P \cdot \eta_t}{p}$$

$$n = \frac{Q}{V \cdot \eta_v} \cdot 10^5$$

$$M = \frac{1.59 \cdot V \cdot p}{\eta_{hm}}$$

$$p = \frac{6 \cdot P \cdot \eta_t}{Q}$$

[%]				
n	η_v	\rightarrow	Q	
M	η_{hm}	\rightarrow	p	
P	η_t	\rightarrow	p · Q	

V [cm ³ /rev]	Q [l/min]	p [bar]	
n [rev/min]	P [kW]	M [Nm]	

提醒： η [%] e.g. 95 [%]

性能曲线

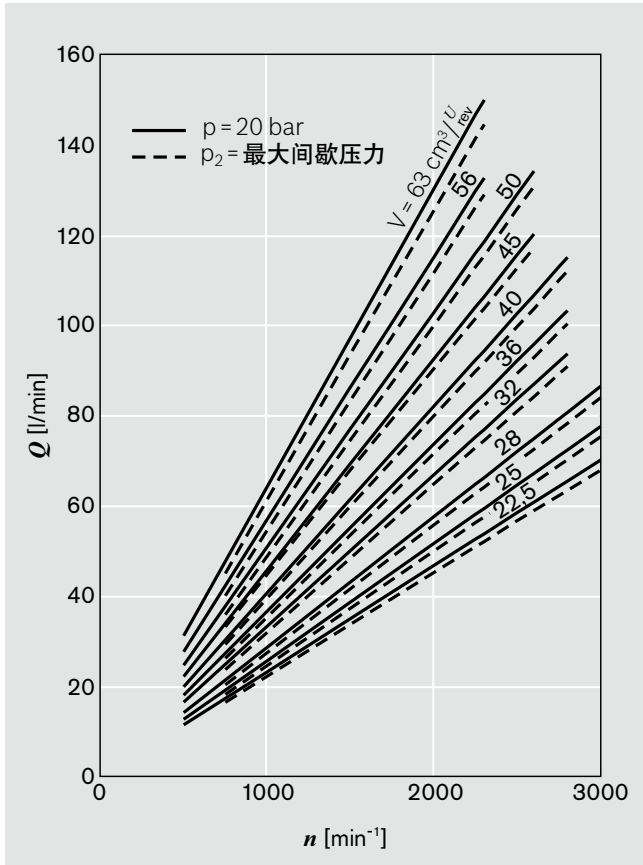

$v = 35 \text{ mm}^2/\text{s}, \dot{\epsilon} = 50 \text{ }^\circ\text{C}$

$Q = f(n, V)$ 包括 h_v
 $P = f(n, p)$ — 包括 h_t
 $M = f(n, p)$ - - - 包括 h_{hm}

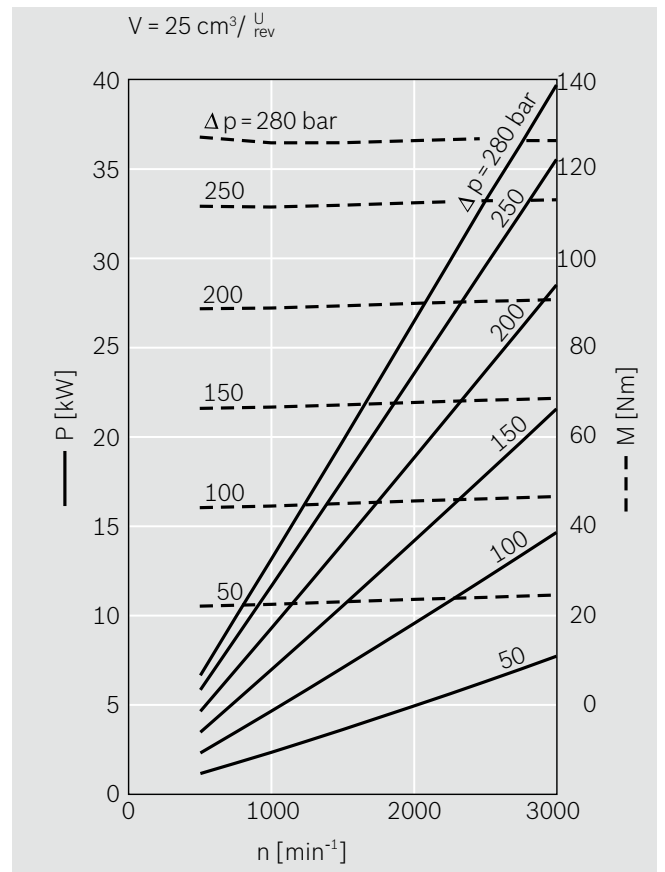
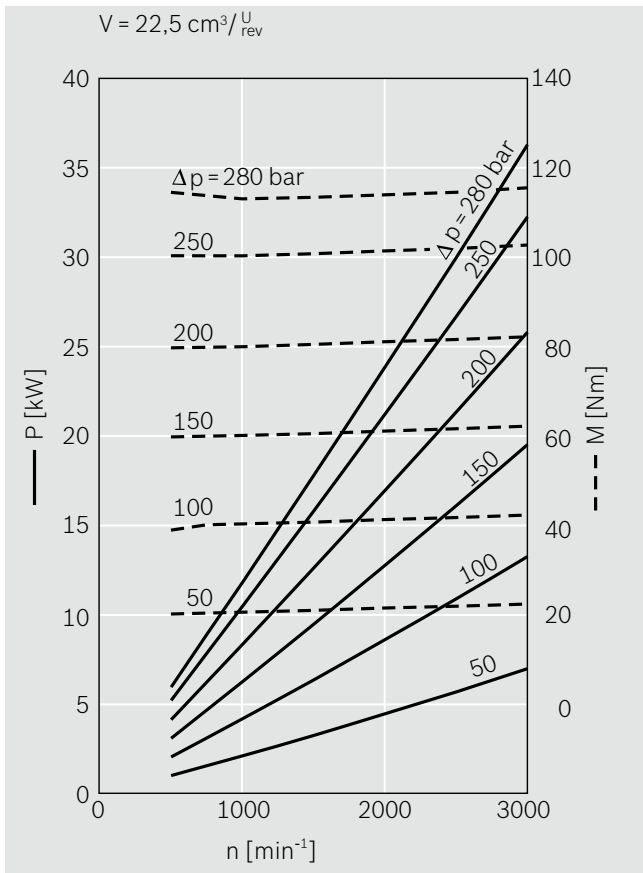

性能曲线 (续)

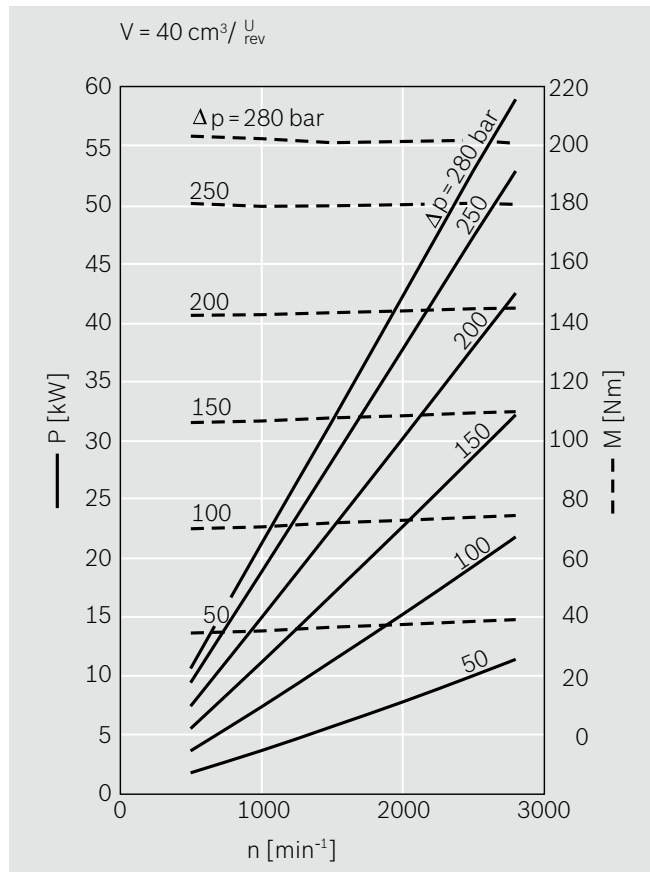
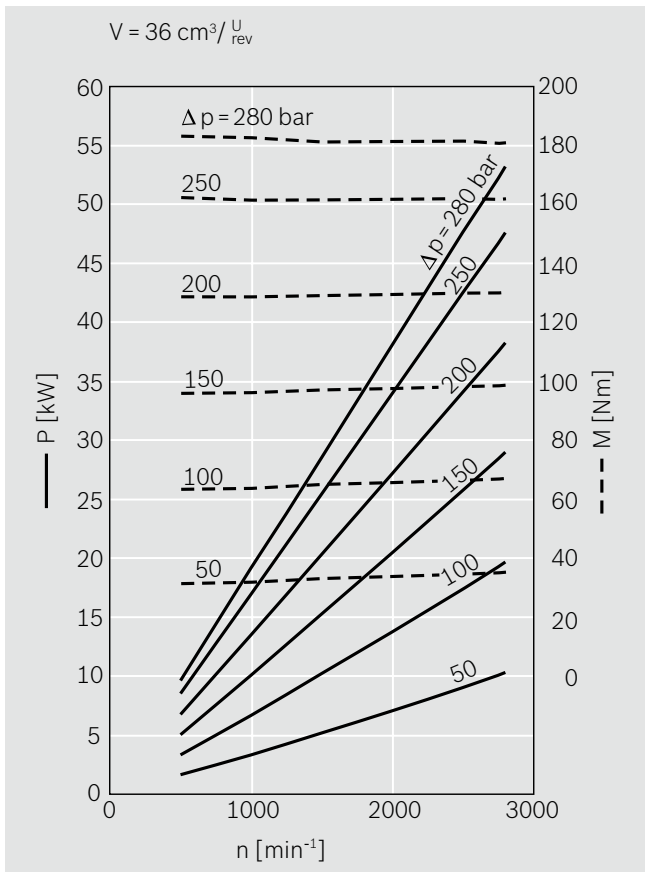
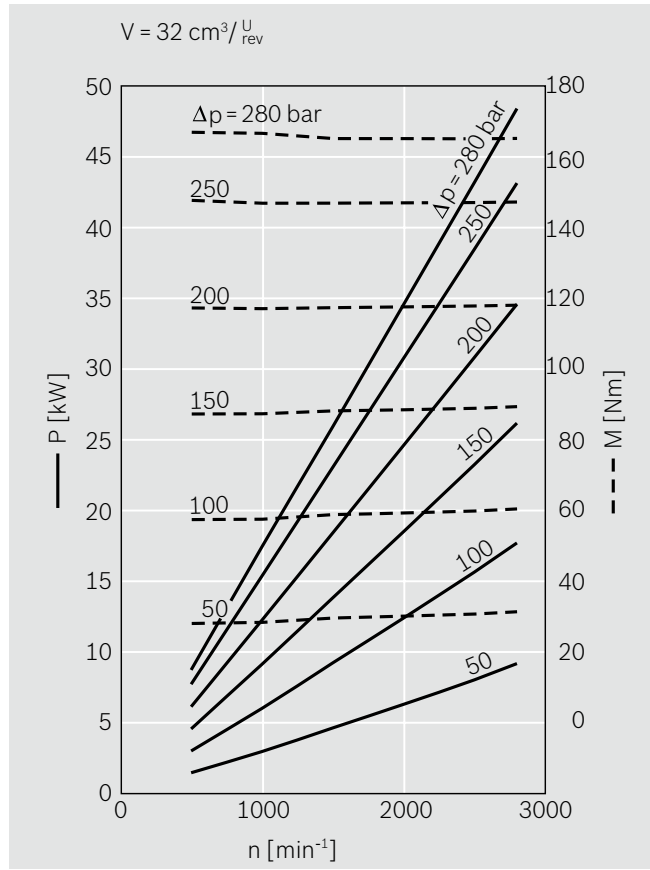
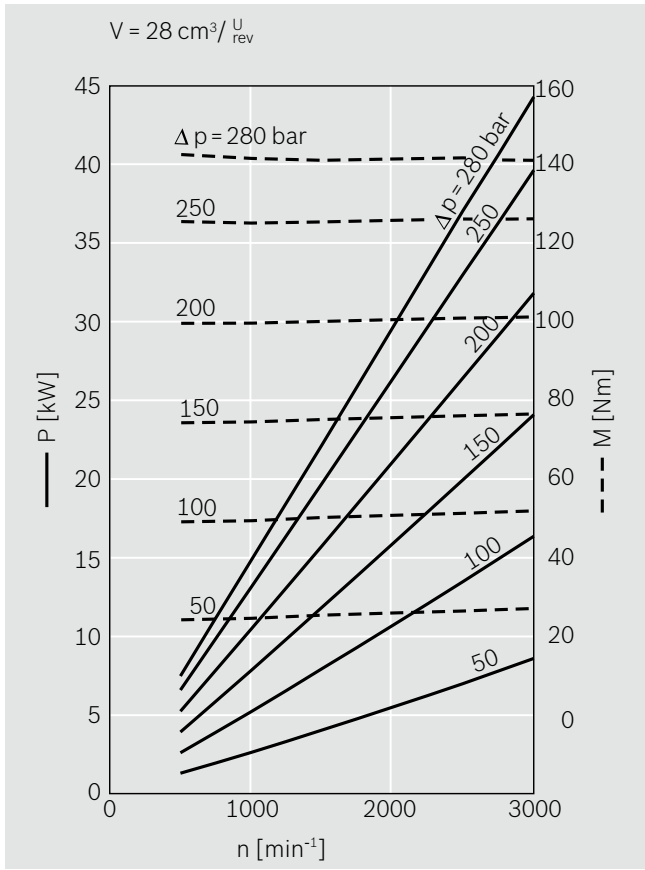

性能曲线 (续)

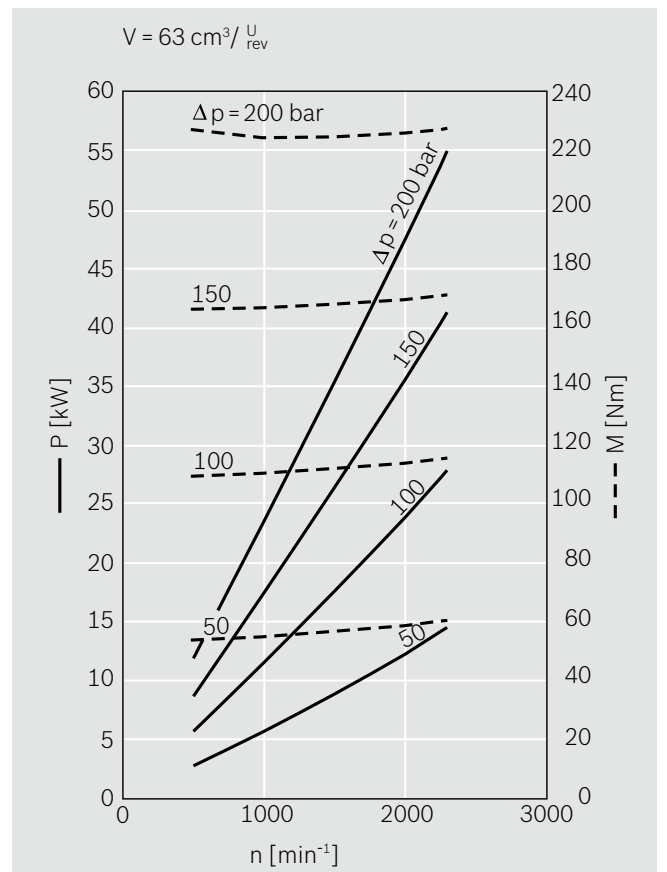
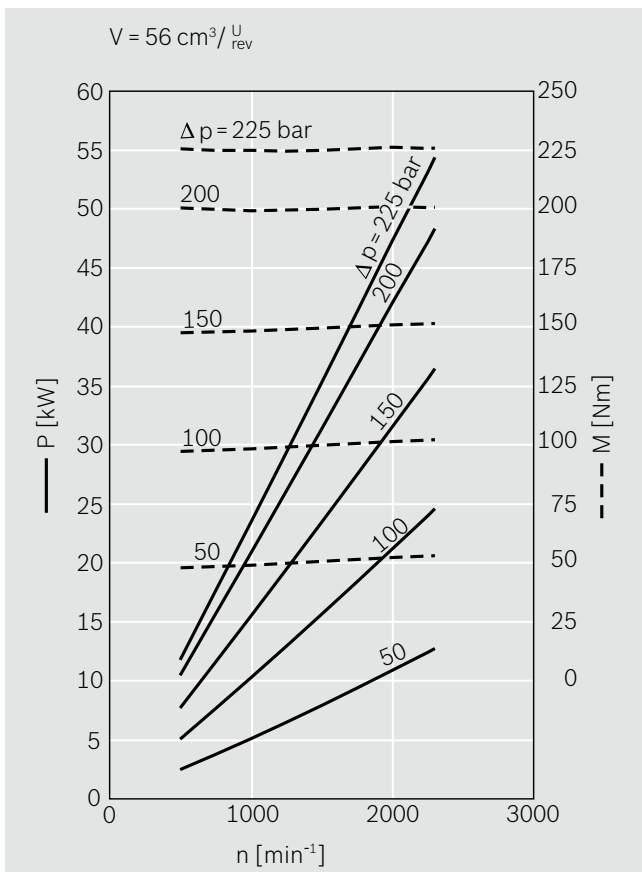
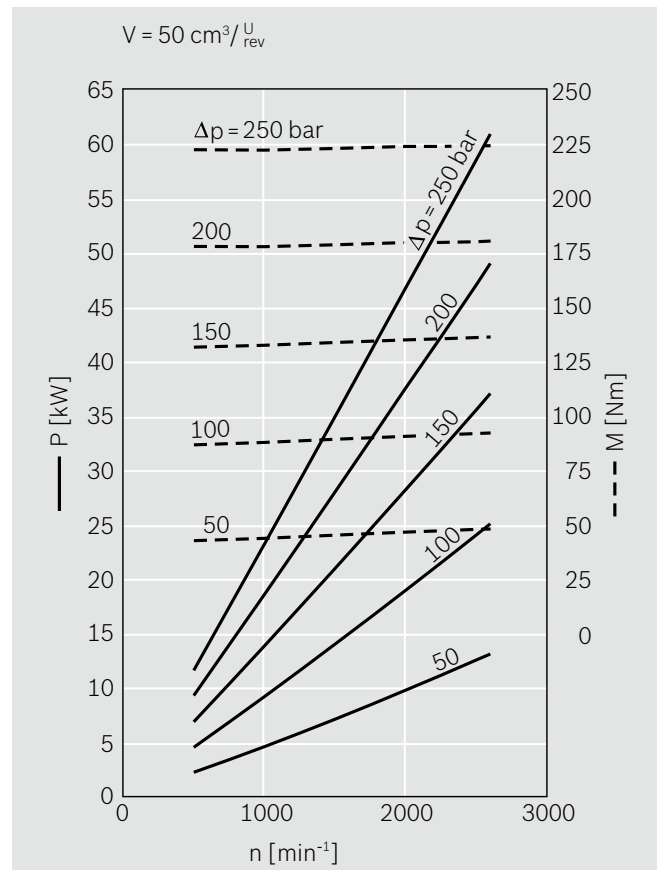
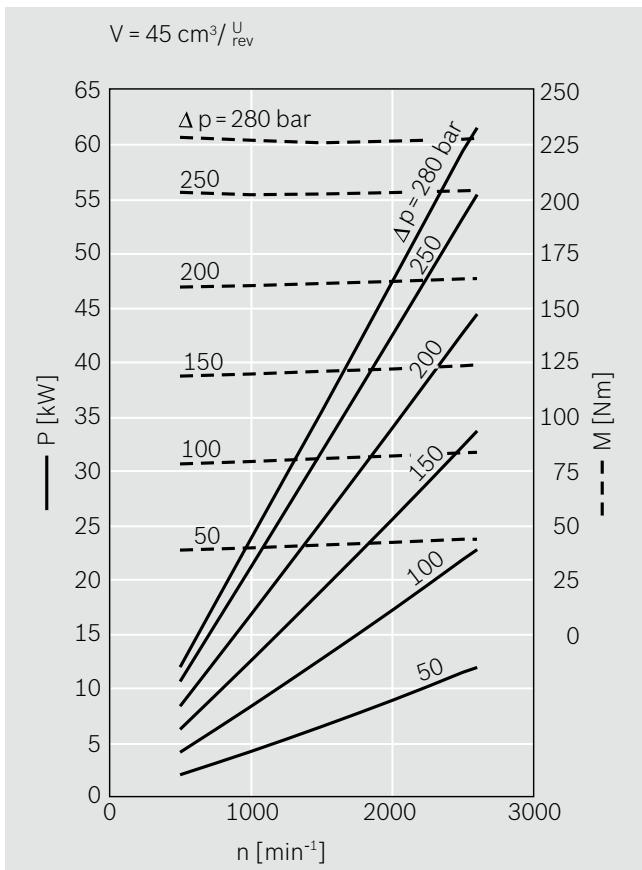

噪音曲线

噪音等级取决于转速和压力范围；这个压力范围介于10 bar和压力值 p_2 （参见第 14 页的规格表）之间。

油液数据： $v = 32 \text{ mm}^2/\text{s}$, $\bar{e} = 50^\circ\text{C}$ 。

对于从吸声测量室测得的噪音值进行计算而得到的声音压力等级，符合 DIN 45635 第 26 章的要求。

测量传感器与液压泵之间的距离：1 米。

这些都是相关型号液压泵的典型特性值。

它们描述了由液压泵单独发出的空气载声。

这里，并没有考虑环境方面的影响（安装现场，管道布置，及其它系统元件）。

这里的每一个数值，分别针对一台单级液压泵。

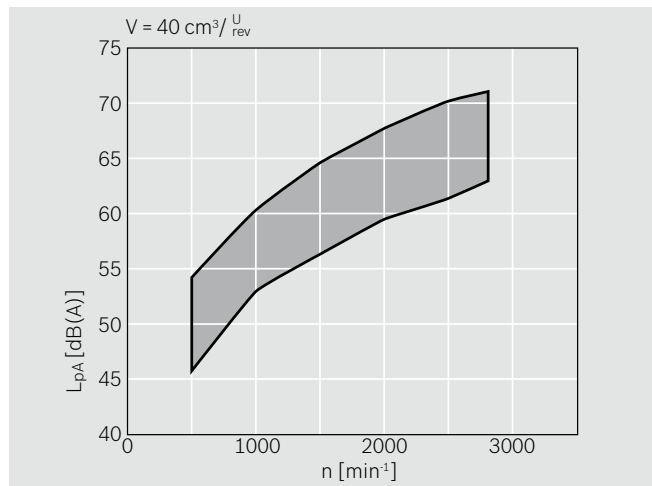
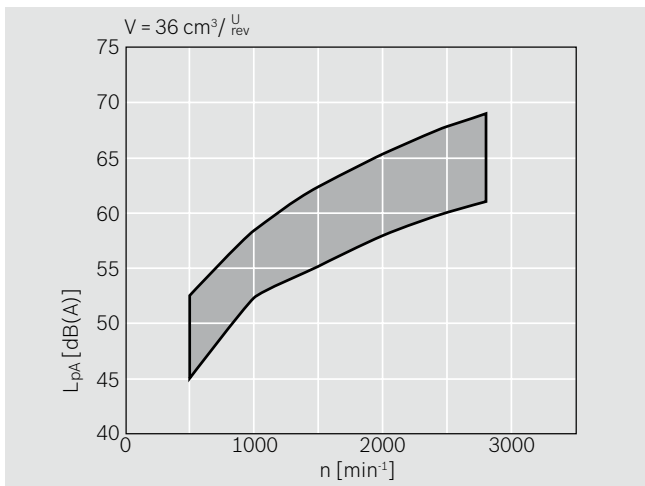
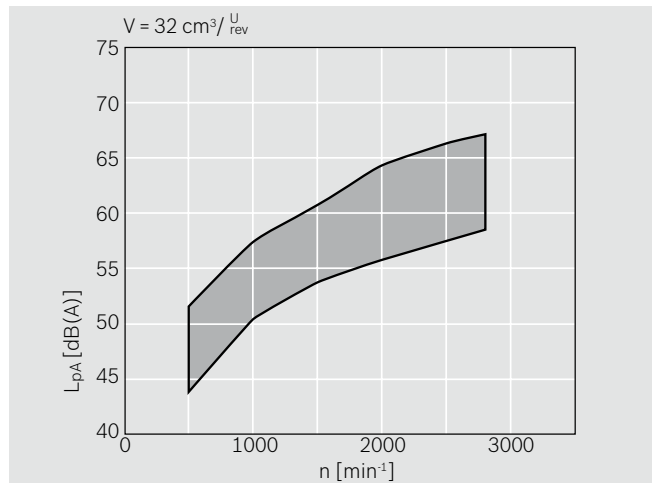
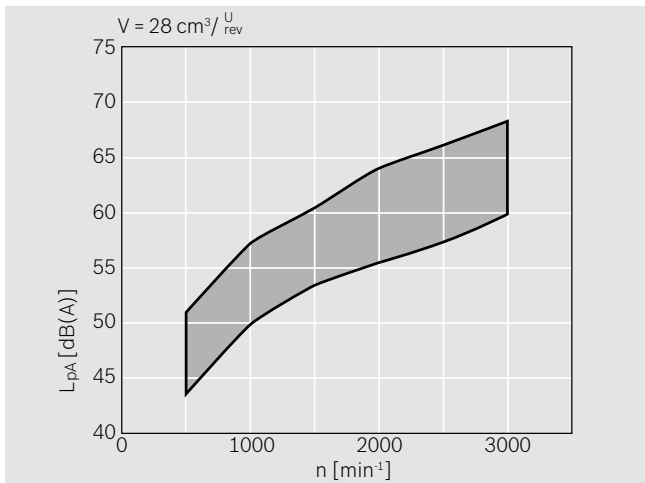
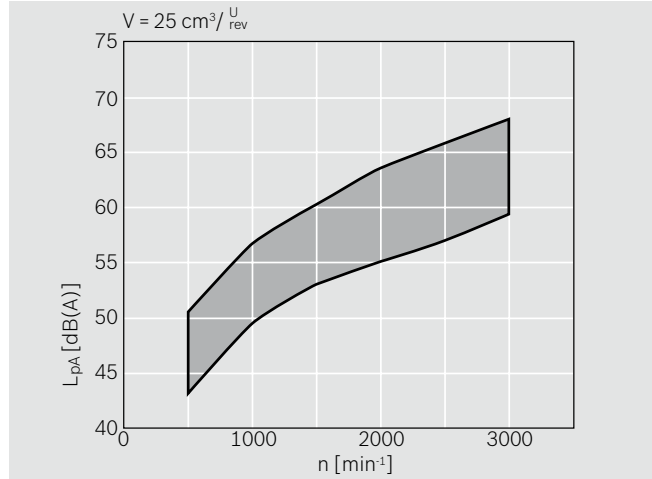
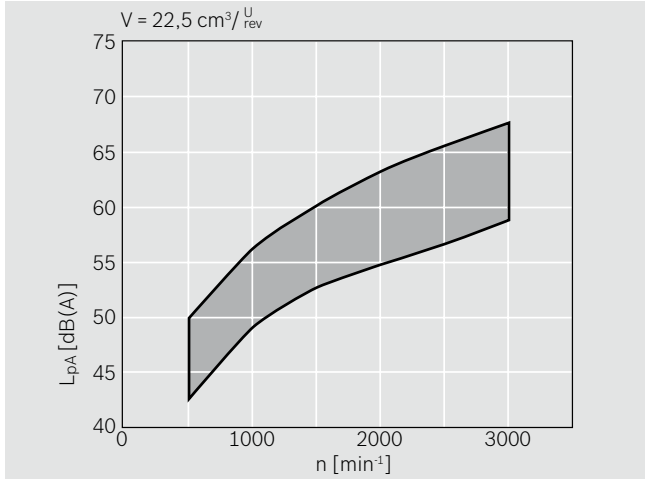

噪音曲线 (续)

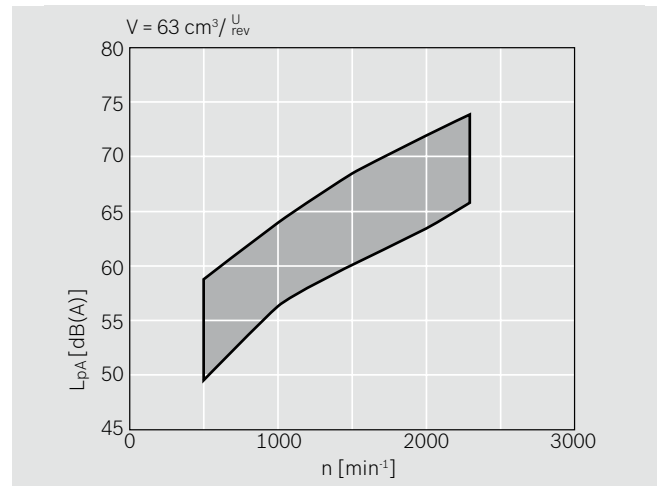
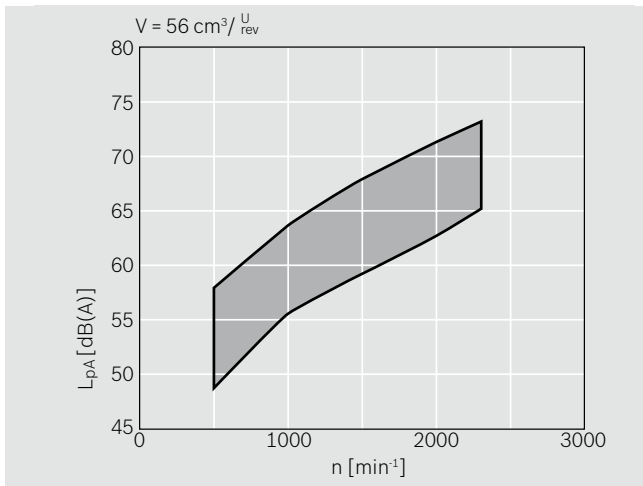
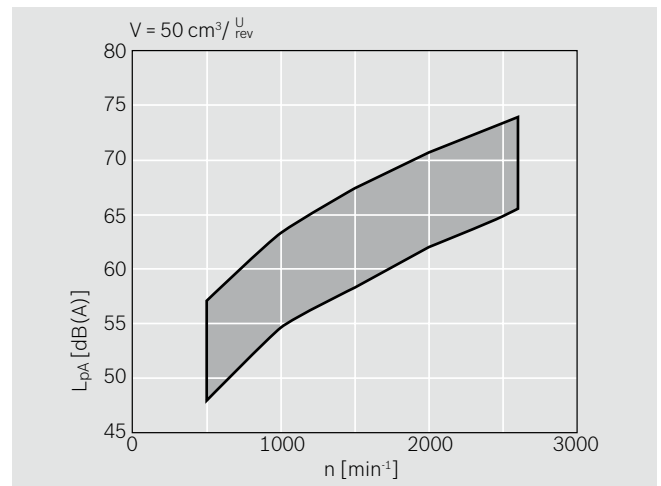
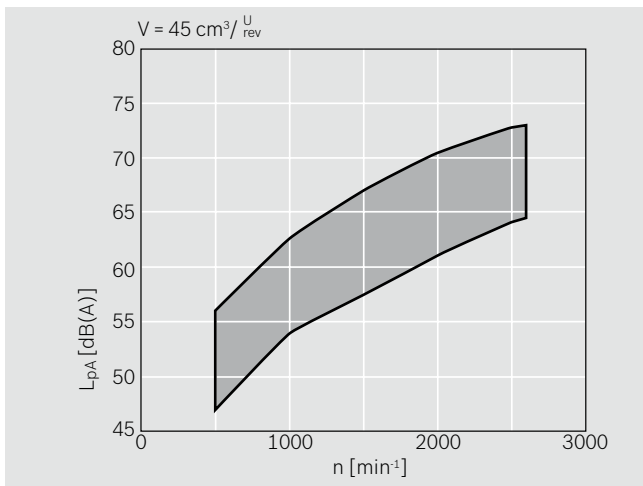

规格

概述	
结构	外啮合齿轮泵
安装	法兰或带有套管的贯穿螺栓
管路油口	法兰
旋转方向 (从轴的视点看)	顺时针或逆时针, 只能以图示的旋转方向驱动这台液压泵
安装位置	任何部位
轴上的负载	径向和轴向力, 待咨询后确定
环境温度范围	-30°C...+80°C, 使用NBR 密封件 -20°C...+110°C, 使用FKM 密封件
液压油	- 矿物油应当符合 DIN 51 524, 1-3; 然而在更高的负载条件下, 至少应采用符合推荐的DIN 51 524章节 2 的HLP 液压流体; - 符合RC 90220 要求; - 经过咨询, 可以采用其它的工作流体
粘度	12...800 mm ² /s, 允许的范围 20...100 mm ² /s, 推荐的范围 ...2000 mm ² /s, 泵的起动所允许的范围
液压油温度范围	-30°C...+80°C -20°C...+110°C, 使用FKM 密封件
过滤 ***)	洁净度等级至少达到 20/18/15, 符合 ISO 4406 (1999)

*** NBR = Perbunan®
 *** FKM = Viton®
 *** 在使用具有重要反作用功能的液压系统或装置 (比如转向与平衡阀)时, 所选过滤类型必须与这些装置或系统的灵敏度相适应。

必须切实遵循整套系统相关联的安全性要求。

如果应用系统需要实现数量很多的负载周期, 则请咨询我们的技术部门。

旋转方向的定义

始终以传动轴的视点观察。

提醒: 在尺寸图纸上, 总是显示顺时针转向的液压泵。对于逆时针旋转的液压泵, 其传动轴的位置、以及吸油口和压力油口的位置都不相同。

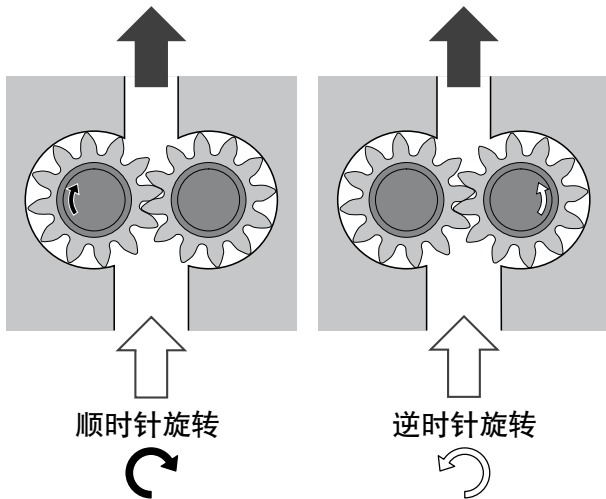

压力的定义

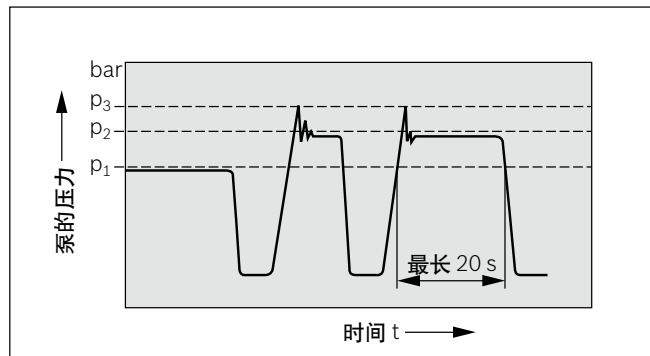

p₁ 最高连续压力
 p₂ 最高间歇压力
 p₃ 最高峰值压力

泵的大小 AZPU

排量	V	cm ³ /rev	22.5	25	28	32	36	40	45	50	56	63	
吸油压力	p _e		0,7...3 (绝对), 使用串联泵: p _e (p ₂) =最大 0.5 > p _e (p ₁)										
最高连续压力	p ₁	bar	250							220	195	170	
最高间歇压力	p ₂		280							250	225	200	
最高峰值压力	p ₃		300							280	250	230	
在以下压力时的最低转速	<100	rpm	500	500	500	500	500	500	500	500	500	500	
			12 mm ² /s	1,200	1,200	1,000	1,000	1,000	800	800	800	800	800
			180... p ₂	1,400	1,400	1,400	1,400	1,200	1,200	1,000	1,000	1,000	1,000
在以下压力时的最高转速	25 mm ² /s	p ₂	600	600	500	500	500	500	500	500	500	500	
			p ₂	3,000	3,000	3,000	2,800	2,800	2,800	2,600	2,600	2,300	2,300

传动系的布置

1. 弹性联轴器

在这种轴联轴合方式下，不得向液压泵传递任何径向力或轴向力。

参见联轴器厂商提供的安装操作规程，以详细了解轴向最大许可的偏差。

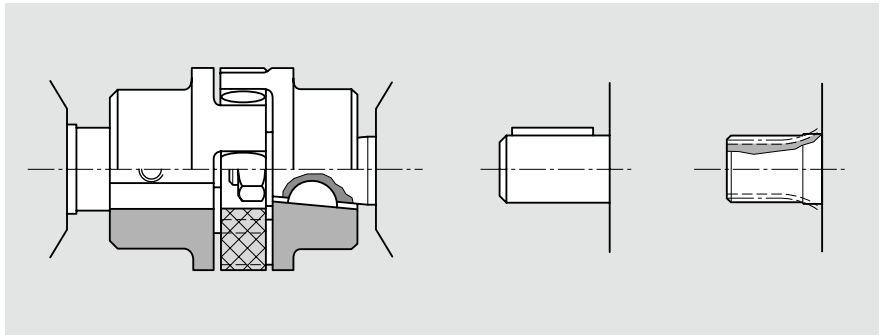

2. 联轴套管

用于DIN 或 SAE花键轴上。

提醒：无论是在泵轴还是联轴套管上，都不得有径向或轴向力的作用。这种联轴套管在轴向必须能移动自如。泵轴与传动轴之间的距离，必须为 $3.5^{+1.5}$ 。需要采用油浴或油雾润滑。

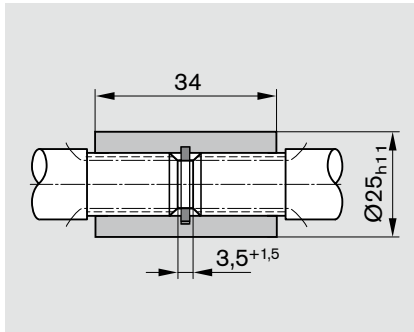

花键轴	订货代码	M _{最大} [Nm]
SAE-B 13 齿	D	300

3. 带柄托的传动轴

通过这种传动轴，液压泵可以紧密联轴电机、或内燃机与齿轮减速器等。泵的传动轴有一个专用的柄托和驱动器③（没有包含在供货内容中）。这里，没有采用轴密封。

推荐的驱动端和密封件的布置与尺寸如下。

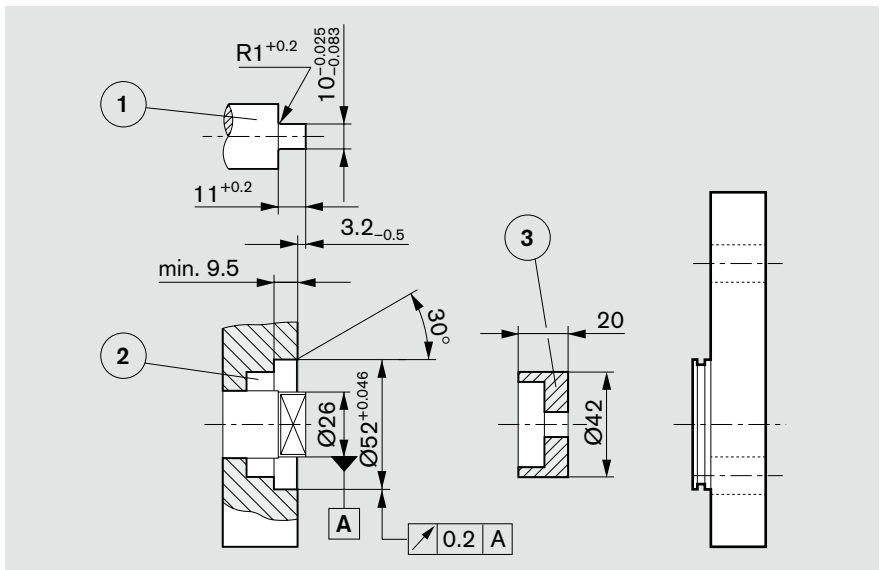

传动轴

泵壳硬化钢 DIN 17210

比如20 MnCrS 5

泵壳硬化层，深1.0；HRA 83^{±2}

针对密封圈的接触面

而进行了无膛线研磨，Rt 4μm

② 径向轴密封件，

采用涂覆橡胶的密封件（参见 DIN 3760，AS 型；或采用双层唇缘密封圈）。

切削一个 15° 的斜角，或者在安装轴密封圈时使用护套。

M _{最大} [Nm]	V [cm ³ /rev]	P _{最大} [bar]
130	28	260
	36	200
	40	180
	45	160
	50	150
	56	130
	63	110
	70	100
	80	90
100	70	

4. 不具外部轴承的 V 形皮带和直齿轮 或螺旋齿的齿轮驱动

请求使用 V 形皮带或齿轮传动时，
请提交该应用的详细信息（尤其是尺寸 a 、 d_m 、 d_w 和角度 α ），以便我们
日后评价。对于螺旋齿齿轮驱动，还需要螺旋角度 β 的详细信息。

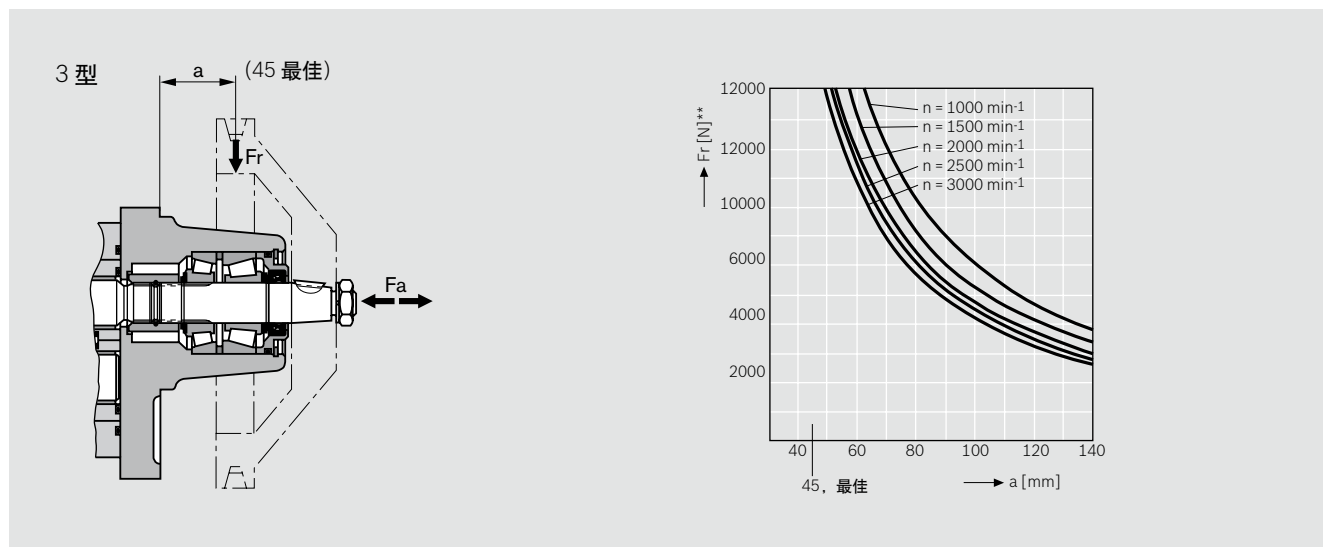

组合齿轮泵

这种齿轮泵非常适合多泵组合的布置方式，一级泵的传动轴延伸到二级泵、甚至三级泵；联轴器安装在每一对液压泵之间。多数情况下，每一台泵与相邻泵都相互隔离，也即各自使用独立的吸油口。作为一种选项，还可以采用一个公用的吸油口。

提醒：基本上采用单级泵的规格，只是有以下这些限制：
最大转速：应当由所使用液压泵中的最高额定转速来确定。
压力：这些限制源于传动轴的强度、以及直接传动和驱动器等因素。相关的数据请参见标有尺寸的图纸。

标准型直接传动期间的压力限制

对于 U 系列的齿轮泵，二级泵送驱动器可传输的最大负载为 $M_{最大} = 130\text{Nm}$ ，也即对二级泵和更多级液压泵有着压力限制。

$M_{最大}$ [Nm]	V [cm ³ /rev]	$p_{最大}$ [bar]
65 F 系列, S 系列	16	230
	19	190
	22.5	160
	25	140
	28	130
130 G 系列, U 系列	22.5	280
	25	280
	28	260
	32	230
	36	200
	40	180
	45	160
	50	150
	56	130
63	110	

如果第一级通过柄托（驱动器）或 1 型外置轴承驱动，那么适用以下公式所述的压力限制。

对于更高的传输扭矩与/或旋转类振动，可以采用加强型直接传动。可按客户要求，定制专用的结构设计。

加强型直接传动

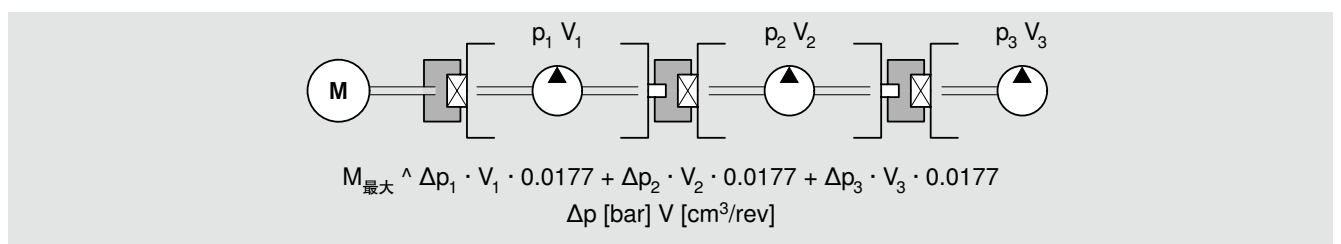
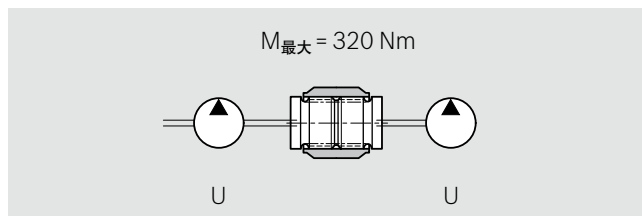

标准型直接传动

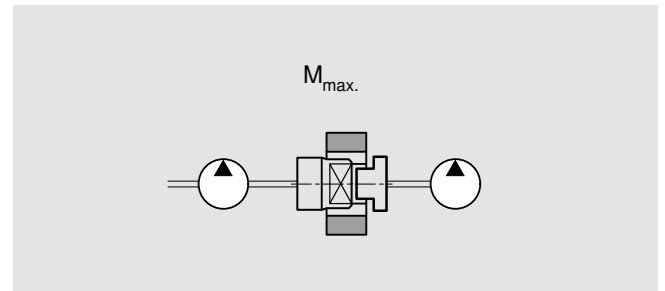

组合泵

系列泵 1	$M_{最大}$ [Nm]	系列泵 2
U	130	G, U
U	65	F, S

在组合泵的配置时，我们建议将最大排量的液压泵置于驱动轴一侧。

可传输的最大驱动扭矩

功能	代码	名称	可传输的最大驱动扭矩 * [Nm]
花键轴	D	SAE J744 22-4 (13T 16/32 DL)	300
	E	SAE-C 15 齿	450
锥形键槽轴	C	1:5	290
	H	1:8	240

* 只有在满足第 15 页至第 16 页所定义的条件时，上述这些数值才适用。如超出相关限值，请咨询博世力士乐。

尺寸

标准范围

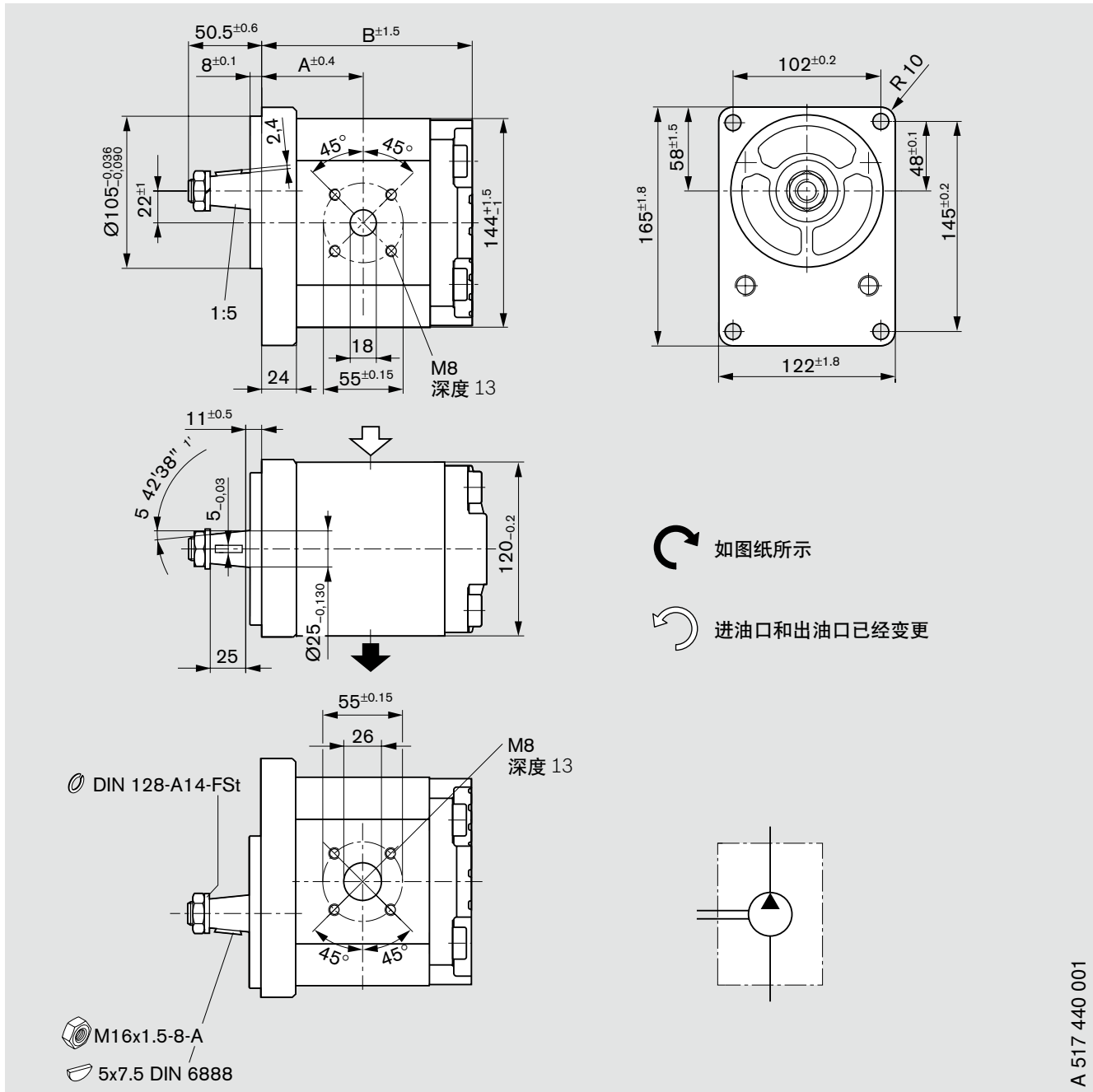

A 517 440 001

订货代码：
AZPU - 22 - n n n n C B 20 M B

排量 [cm ³ /rev]	订货代码		最高工作压力 [bar]	最高转速 [rpm]	重量 [kg]	尺寸 [mm]	
	左	右				A	B
22.5	0 517 725 322	0 517 725 026	280	3,000	10.3	60.9	124.6
25	0 517 725 323	0 517 725 027	280	3,000	10.4	61.9	126.6
28	0 517 725 324	0 517 725 028	280	3,000	10.5	63.2	129.1
32	0 517 725 325	0 517 725 029	280	2,800	10.7	64.8	132.4
36	0 517 725 326	0 517 725 030	280	2,800	10.9	66.4	135.7
40	0 517 725 327	0 517 725 031	280	2,800	11.0	68.1	139.0
45	0 517 725 328	0 517 725 032	280	2,600	11.2	70.1	143.1
50	0 517 825 301	0 517 825 001	250	2,600	11.4	72.2	147.2
56	0 517 825 302	0 517 825 002	225	2,300	11.7	74.7	152.2
63	0 517 825 303	0 517 825 003	200	2,300	12.0	77.6	158.0

尺寸

标准范围

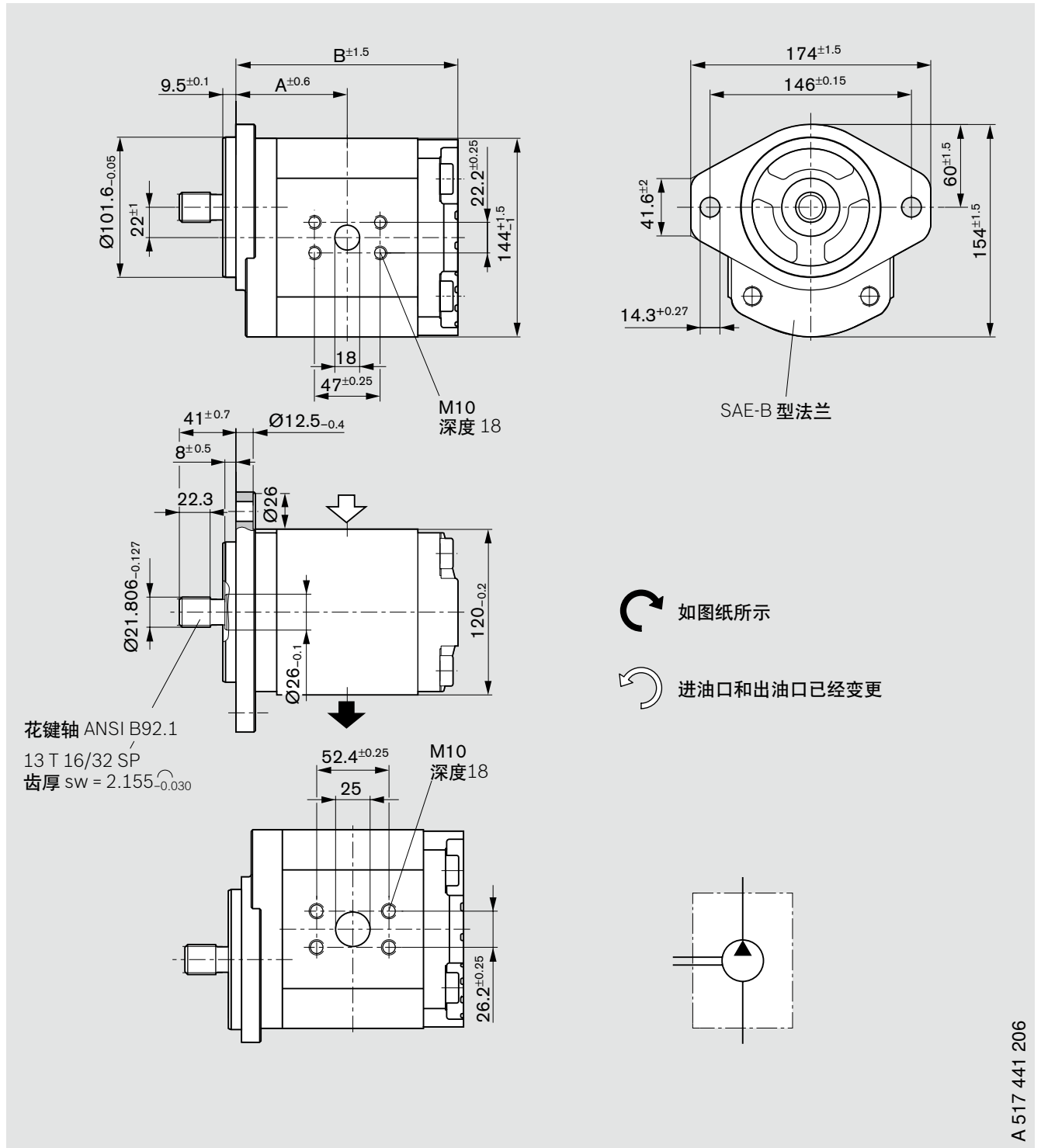

订货代码：
AZPU-22-nnn nDC 07 KB

排量 [cm ³ /rev]	订货代码		最高工作压力 pressure [bar]	最高转速 [rpm]	重量 [kg]	尺寸 [mm]	
	左	右				A	B
22.5	0 517 725 329	0 517 725 033	280	3,000	9.6	66.4	130.1
25	0 517 725 330	0 517 725 034	280	3,000	9.7	67.4	132.1
28	0 517 725 331	0 517 725 035	280	3,000	9.8	68.7	134.6

尺寸

标准范围

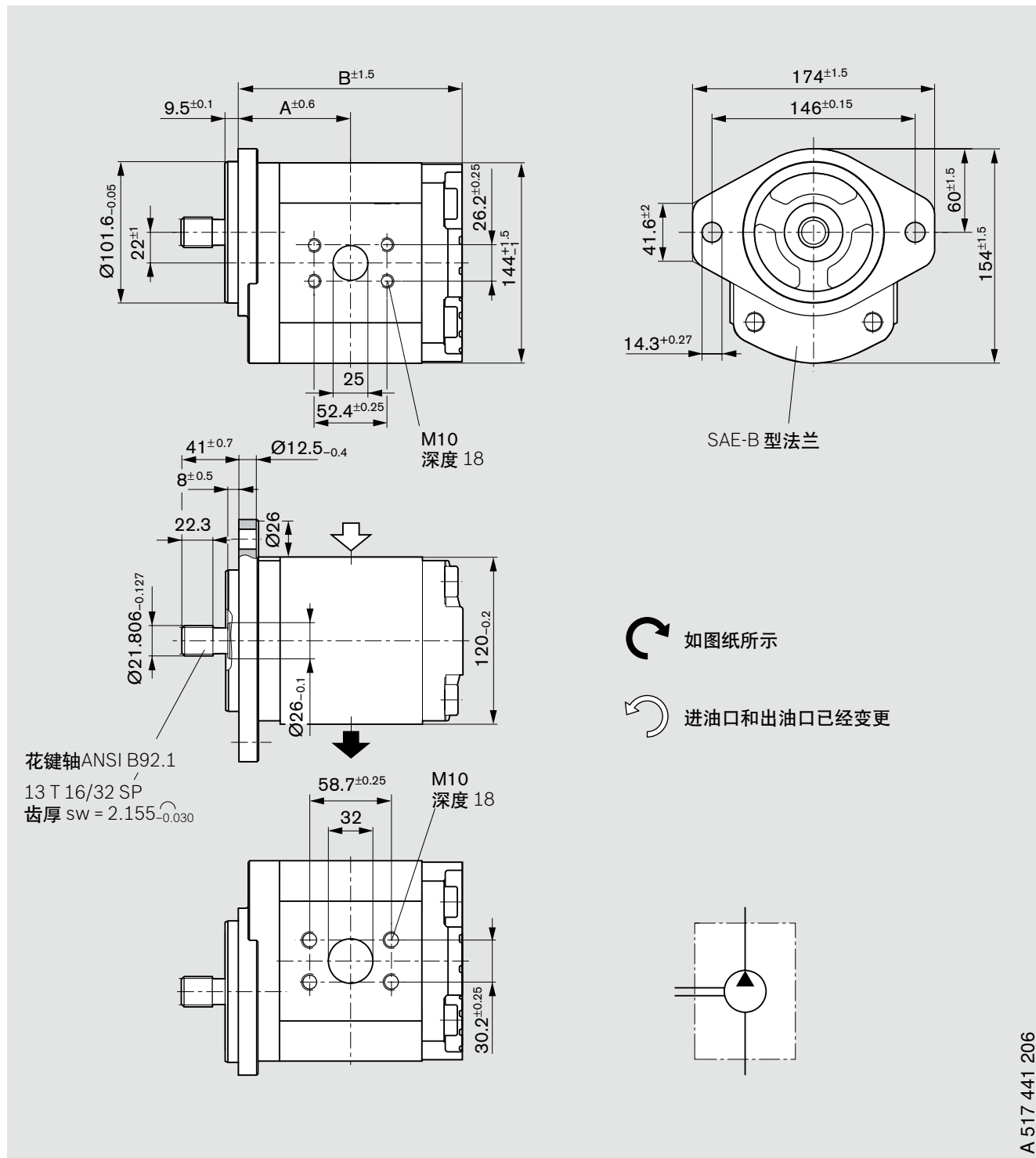

A 517 441 206

订货代码：
AZPU - 22 - nnn nDC 07 KB

排量 [cm ³ /rev]	订货代码		最高工作压力 pressure [bar]	最高转速 [rpm]	重量 [kg]	尺寸 [mm]	
	左	右				A	B
32	0 517 725 332	0 517 725 036	280	2,800	10.0	70.3	137.9
36	0 517 725 333	0 517 725 037	280	2,800	10.1	71.9	141.2
40	0 517 725 334	0 517 725 038	280	2,800	10.3	73.6	144.5
45	0 517 725 335	0 517 725 039	280	2,600	10.5	75.6	148.6
50	0 517 825 304	0 517 825 004	250	2,600	10.7	77.7	152.7

尺寸 标准范围

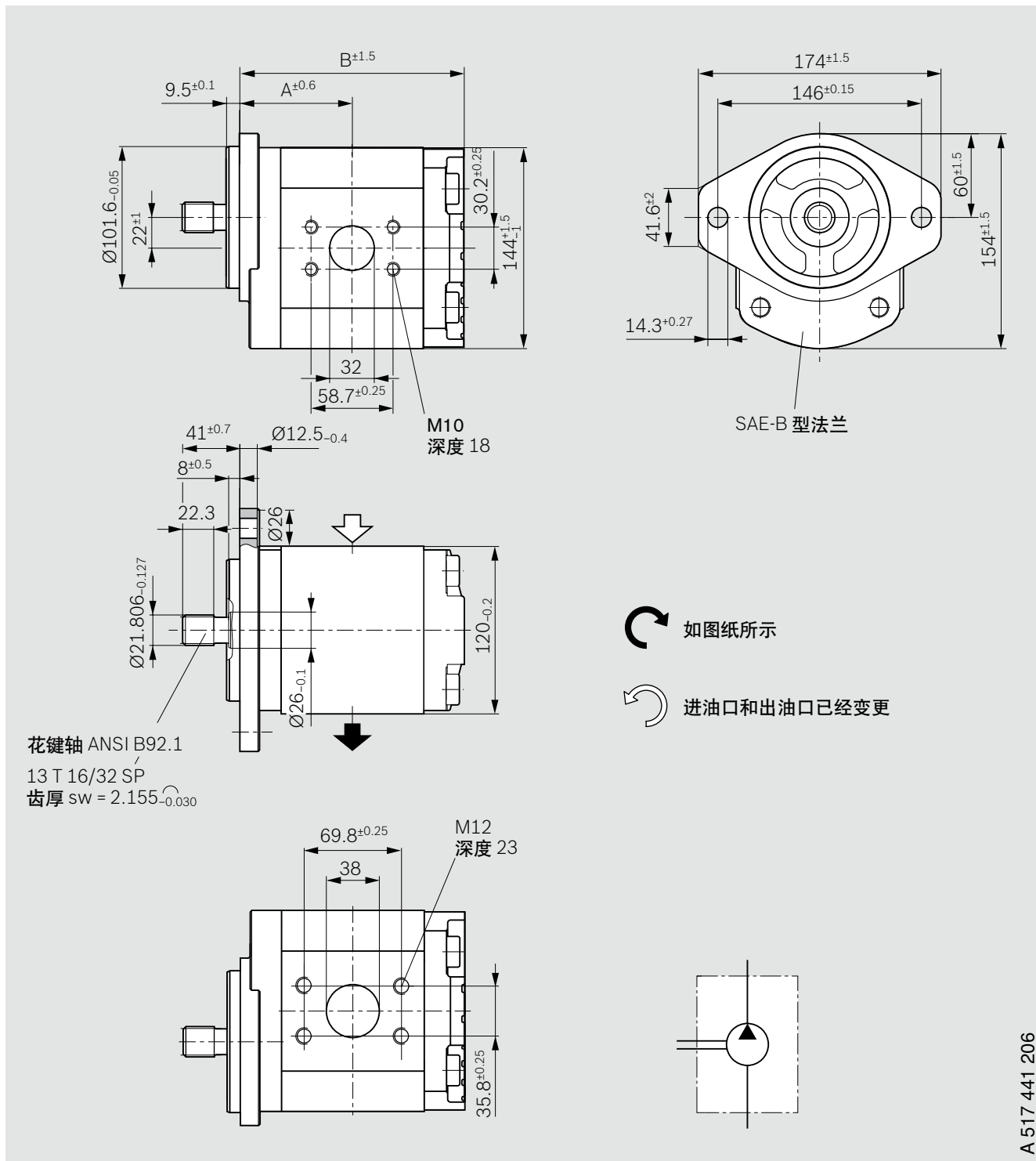

订货代码：
AZPU-22-nnn nDC07KB

排量 [cm ³ /rev]	订货代码		最高工作压力 [bar]	最高转速 [rpm]	重量 [kg]	尺寸 [mm]	
	左	右				A	B
56	0 517 825 305	0 517 825 005	225	2,300	11.0	80.2	157.7
63	0 517 825 306	0 517 825 006	200	2,300	11.3	83.1	163.5

配件

这些配件可用于矩形法兰 20，请参见第 7 页
齿轮泵的法兰，90°角

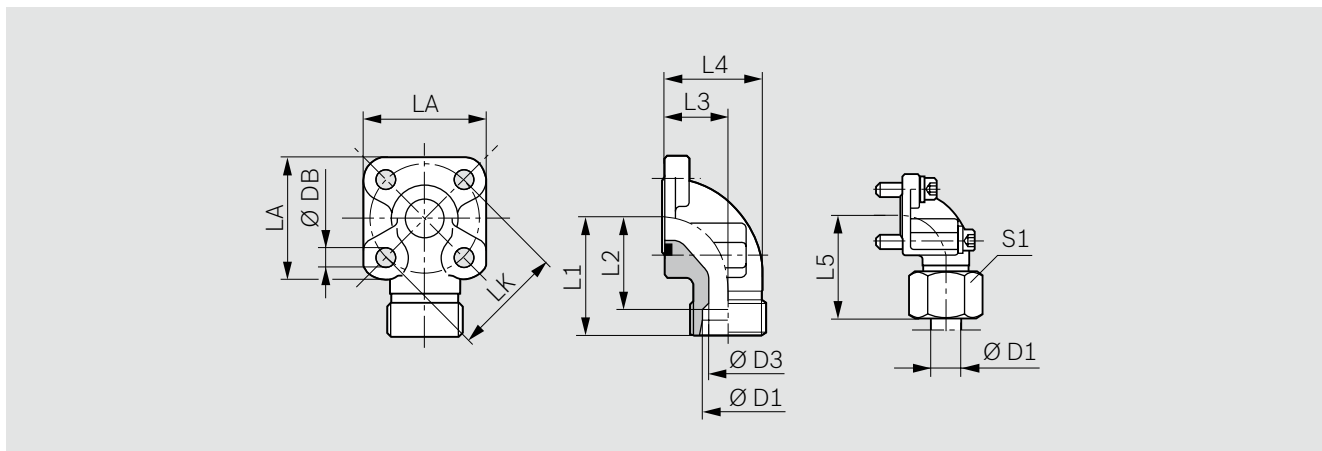

LK	D1	D3	L1	L2	L3	L4	L5	LA	S1	DB	螺栓 2x		密封圈	重量 kg	部件号	压力p (bar)
55	20S	17	45	34.5	24.0	40.0	56.0	58	36	8.4	M8x25	M8x50	33x2.5	0.44	1 515 702 004	250
55	30S	26	49	35.5	32.0	50.0	62.0	58	50	8.4	M8x25	M8x50	33x2.5	0.50	1 515 702 006	250
55	35L	31	49	38.5	32.0	51.5	62.0	58	50	8.4	M8x25	M8x60	32x2.5	0.47	1 515 702 005	100
55	42L	38	49	38.0	40.0	64.5	61.0	58	60	8.4	M8x25	M8x70	32x2.5	0.60	1 515 702 019	100

完整的配件，带有密封圈、公制螺栓套件、螺母和凸台。

备注

您可以在我们的下述出版物中，找到许可的紧固扭矩值：
"外啮合设备的一般操作说明" RC 07 012-B1.

调试注意事项

滤油方式建议

外啮合齿轮泵的大部分故障案例均由污染的液压油所导致。鉴于保修条款并不涵盖污染所造成的磨损，所以建议采用符合洁净度水平 20/18/15 ISO 4406 的过滤方式，从而在污染颗粒大小和浓度方面将污染降至容许的级别：

工作压力 [bar]	>160	<160
污染度等级 ISO 4406	18/15	19/16
需要达到的水平 $\beta_x = 75$	20	25

我们建议：应始终采用全流量滤油器。根据 ISO 4406 的要求，液压油的基本污染不得超出等级 20/18/15。过去的经验表明，新的油液往往都高于这一限值。在这种情况下，应使用带有专用滤油器的注油装置。

概述

- 在液压泵交货之前，我们已检查了相关的功能和性能。请勿擅自改动泵的任何部分，否则会造成保修条款失效！
- 泵的运行，必须符合许可的相关技术数据 (参见 15 到 18 页)。

项目规划注意事项

在“液压技术培训” 3 RE 00 281 的“项目规划注意事项和液压系统的设计”中，收录了完整的注意事项和建议。对于外啮合齿轮泵的用户，我们建议切实遵循以下事项。

技术数据

所有相关的技术数据都取决于生产公差，只在特定的边际条件下才有效。

请注意：由于上述原因，可能会产生一种散射效应；因此在某些边际条件下 (比如粘度)，这些技术数据可能会发生改变。

特性

在设计外啮合齿轮泵时，应根据 10 到 12 页中显示的产品特性，记下最大的可能维护数据。

关于正确使用博世力士乐液压产品的更多信息，请参见我们的文件：“液压产品的一般信息” RE 07 008。

交货时的相关资料

交货时会包含具有 18 到 21 页的订货代码和设备测量数据下所描述的特性的元件。

在我们出版的资料 RC07 012-B1“外啮合设备的一般操作说明”中，您可以找到更多内容。

维修零部件

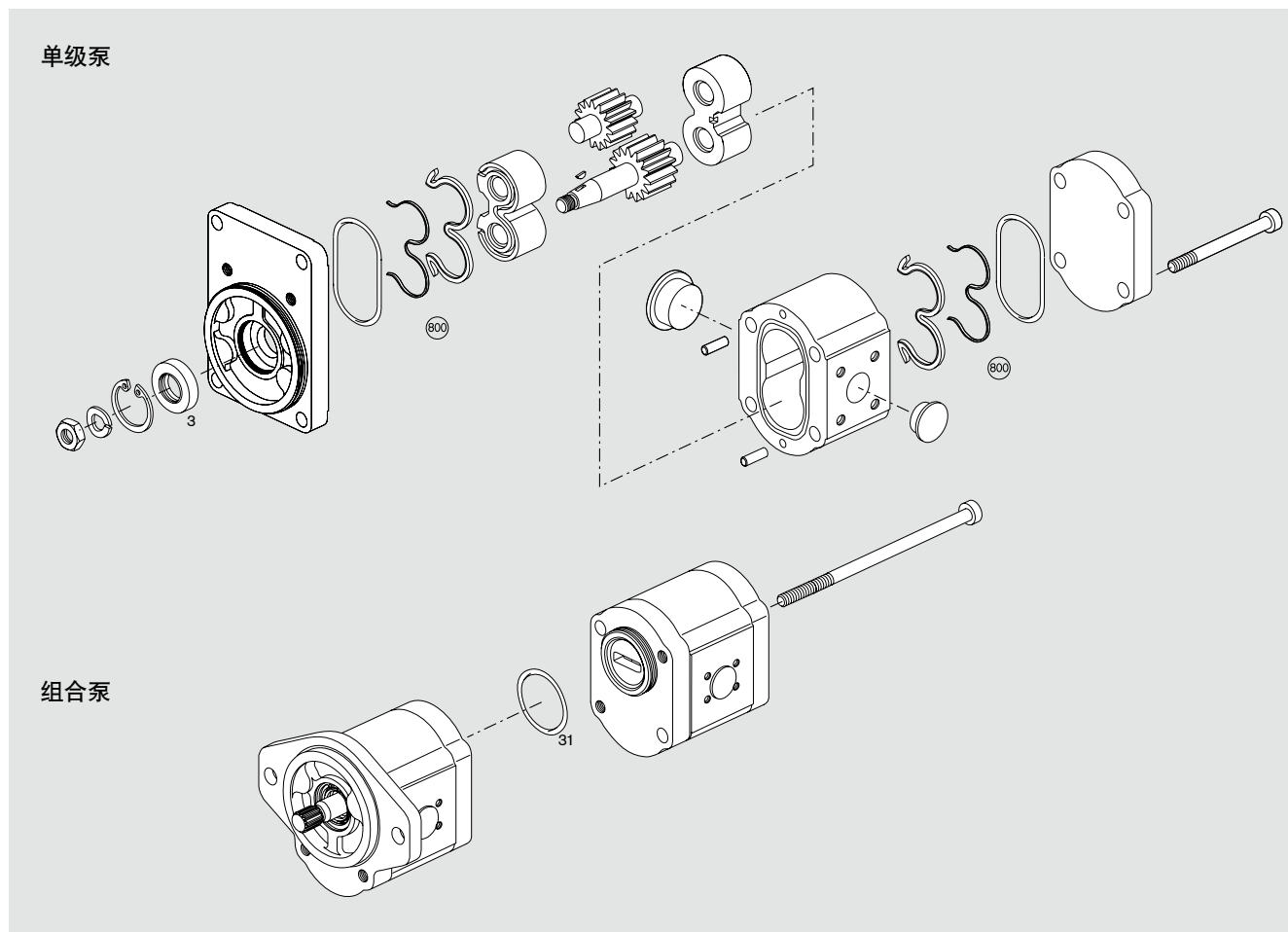

页号	订货代码	“U”密封套件 位置# 800 NBR	轴密封圈 位置 #3	尺寸	材料
18	AZPU – 22 – nnn n C B 20 M B	1517010231	1510283072	42x 26x 7	NBR
19, 20, 21	AZPU – 22 – nnn n D C 07 K B	1517010231	1510283069	42x 26x 7	FKM

NBR = Perbunan® FKM = Viton®

对于组合泵	密封圈 位置 # 31 NBR	1900210145
-------	-----------------------	------------

AZ 配置工具, 网址: www.boschrexroth.com/azconfigurator

有了AZ 配置工具, 就能以方便、用户友好的方式帮助你配置每一台外啮合设备。你只需规定自己的要求: 从泵的排量、旋转方向、传动轴、连接法兰, 一直到必要的后盖。一旦你的配置早已存在, 你就会立即收到一张项目图纸 (PDF 格式); 一旦需要, 你还会收到配置后的外啮合设备的价格。

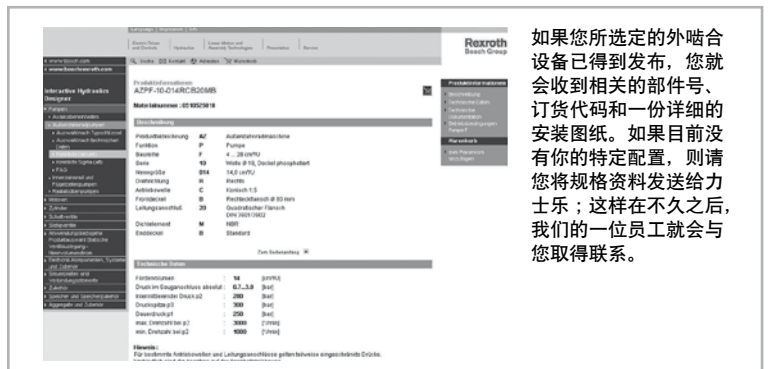
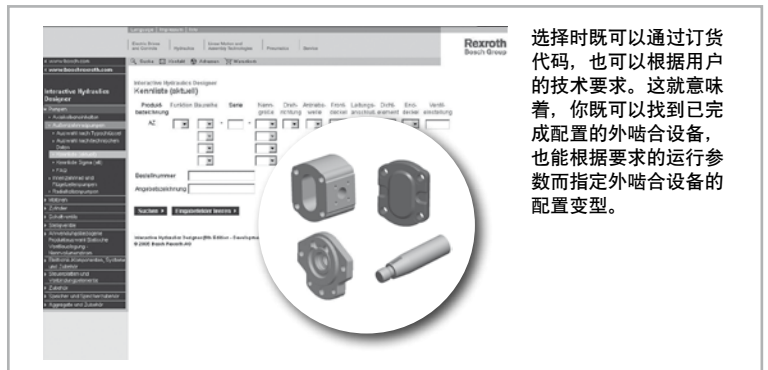

订货代码

订货代码	页号	订货代码	页号	订货代码	页号
0 517 725 004	20	0 517 725 039	20	0 517 725 334	20
0 517 725 026	18	0 517 725 304	20	0 517 725 335	20
0 517 725 027	18	0 517 725 322	18	0 517 825 001	18
0 517 725 028	18	0 517 725 323	18	0 517 825 002	18
0 517 725 029	18	0 517 725 324	18	0 517 825 003	18
0 517 725 030	18	0 517 725 325	18	0 517 825 005	21
0 517 725 031	18	0 517 725 326	18	0 517 825 006	21
0 517 725 032	18	0 517 725 327	18	0 517 825 301	18
0 517 725 033	19	0 517 725 328	18	0 517 825 302	18
0 517 725 034	19	0 517 725 329	19	0 517 825 303	18
0 517 725 035	19	0 517 725 330	19	0 517 825 305	21
0 517 725 036	20	0 517 725 331	19	0 517 825 306	21
0 517 725 037	20	0 517 725 332	20		
0 517 725 038	20	0 517 725 333	20		